

BOX FRAME ASSEMBLY

REAR VIEW

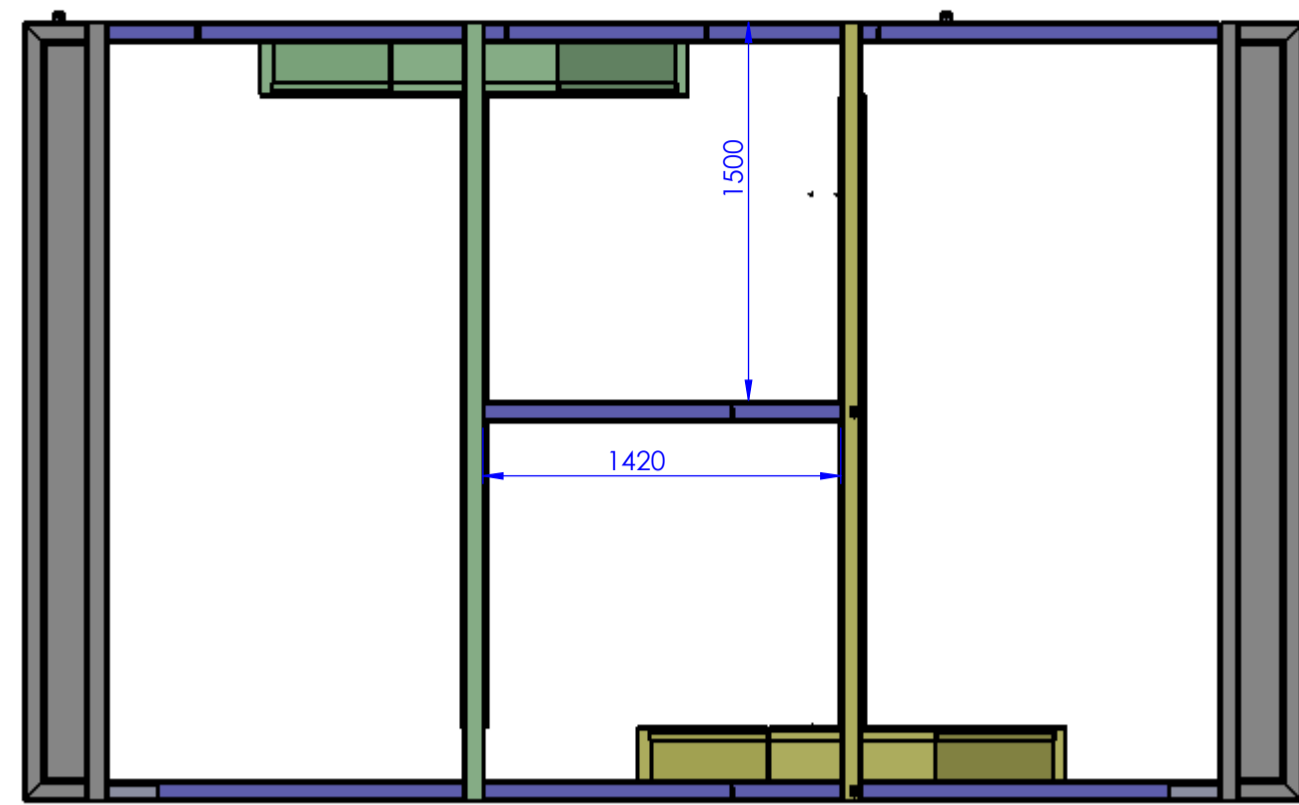

A

FRONT VIEW

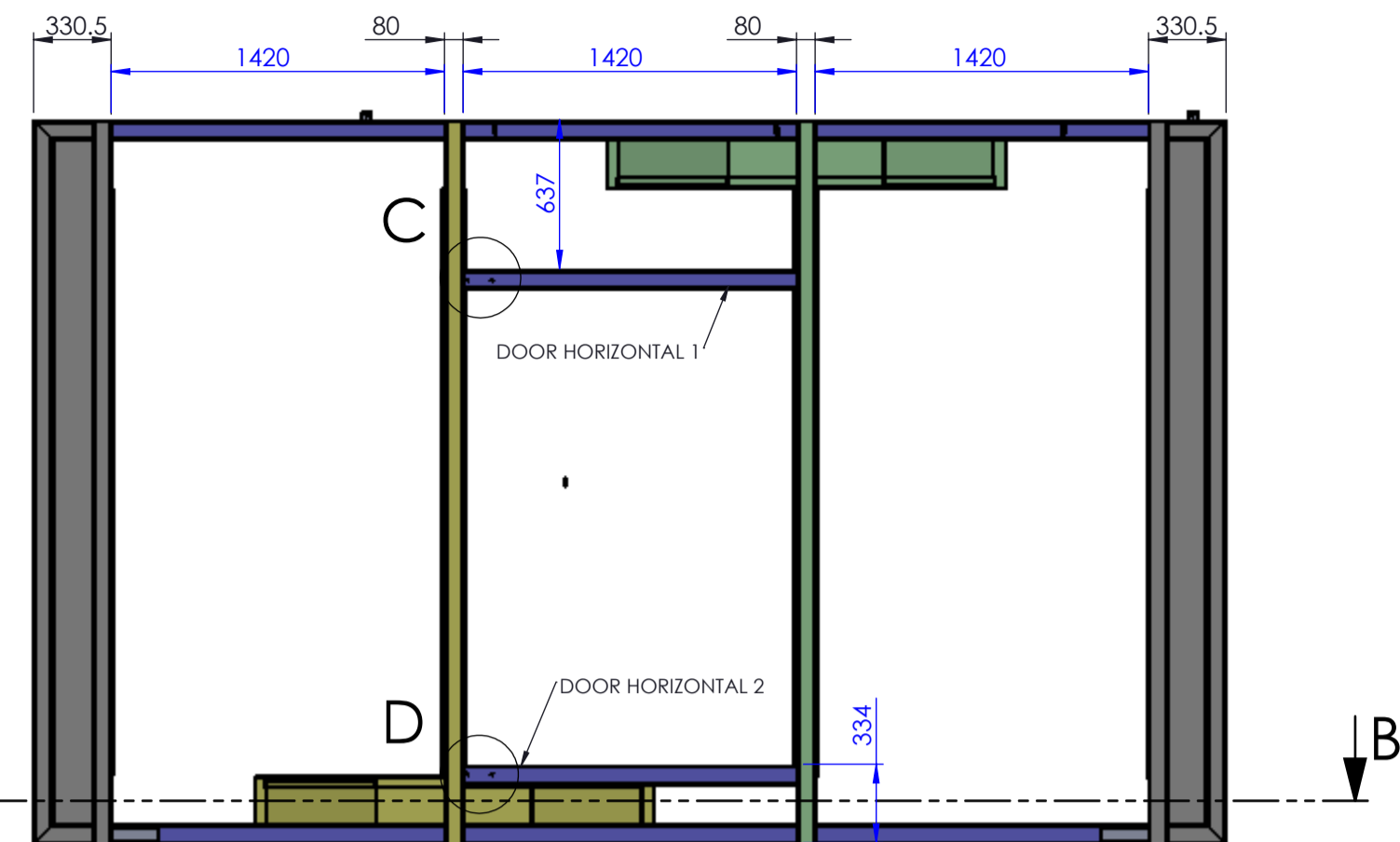

A

B

B

DOOR HORIZONTAL 1 - STUD DETAILS

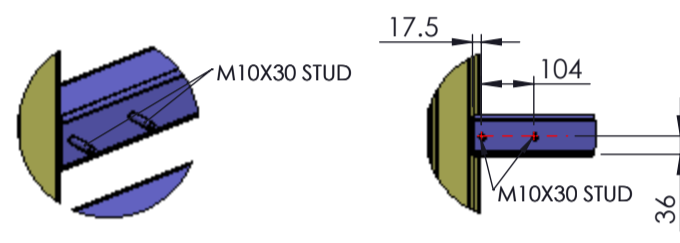

DETAIL E

DOOR HORIZONTAL 2 - STUD DETAILS

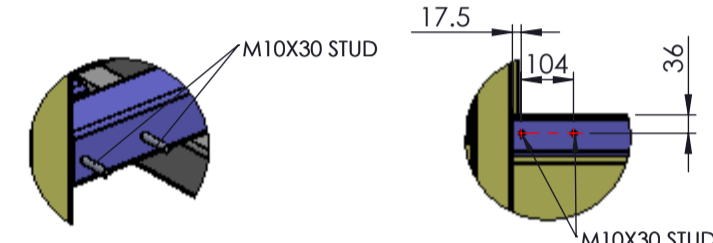

DETAIL D

SECTION A-A - ROOF LEVEL PLAN VIEW

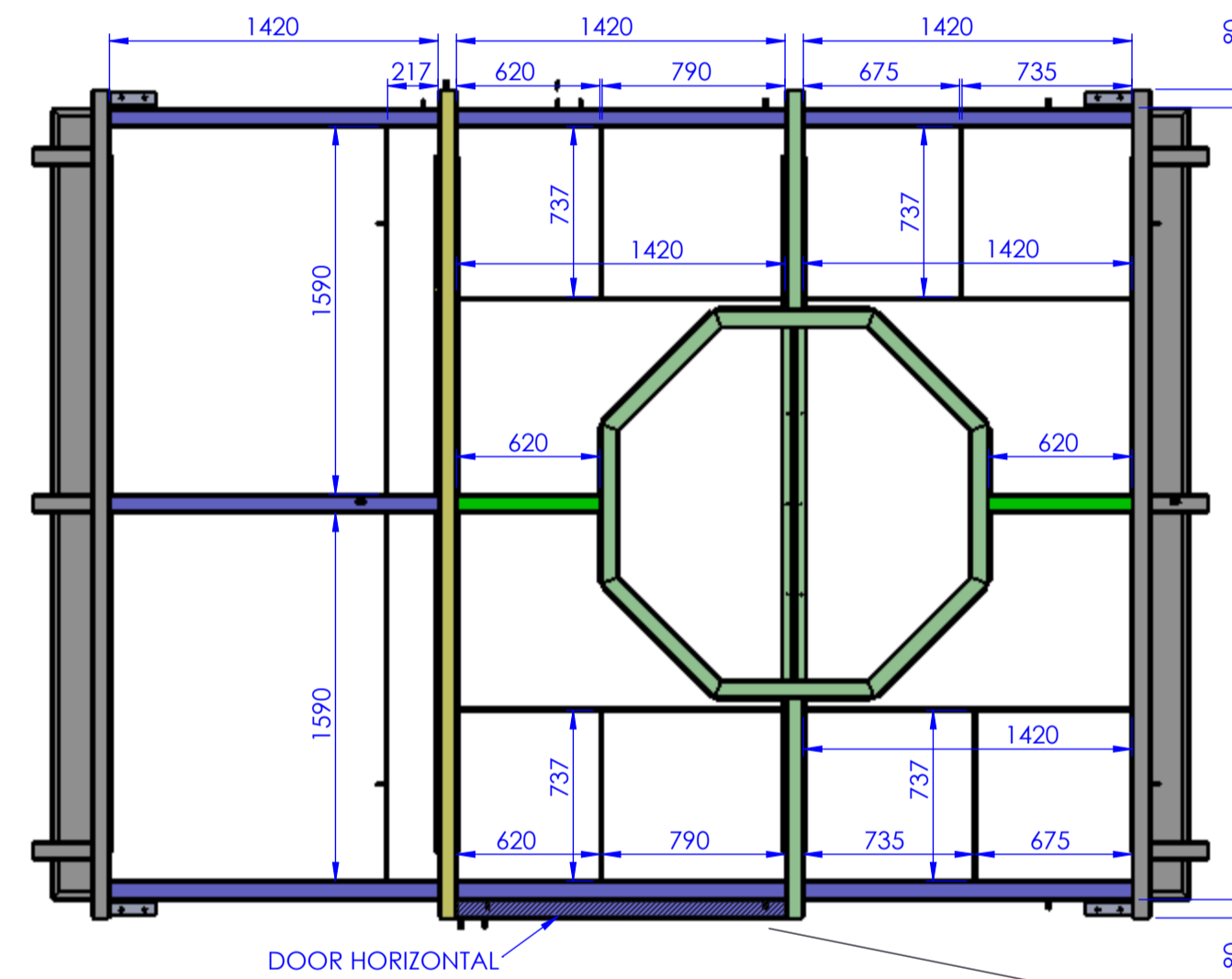

FULL FRAME ASSEMBLY

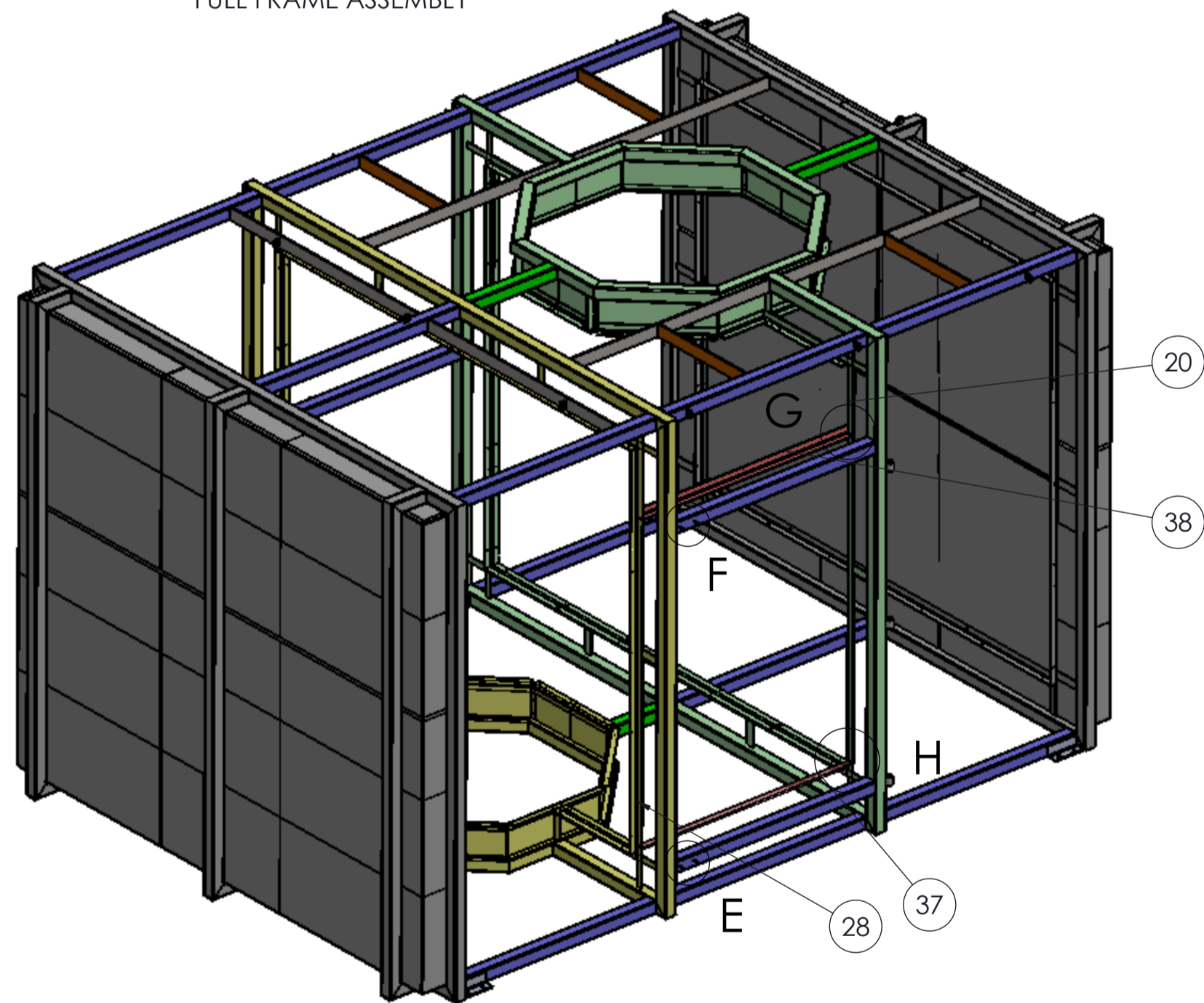

SECTION B-B - FLOOR LEVEL PLAN VIEW

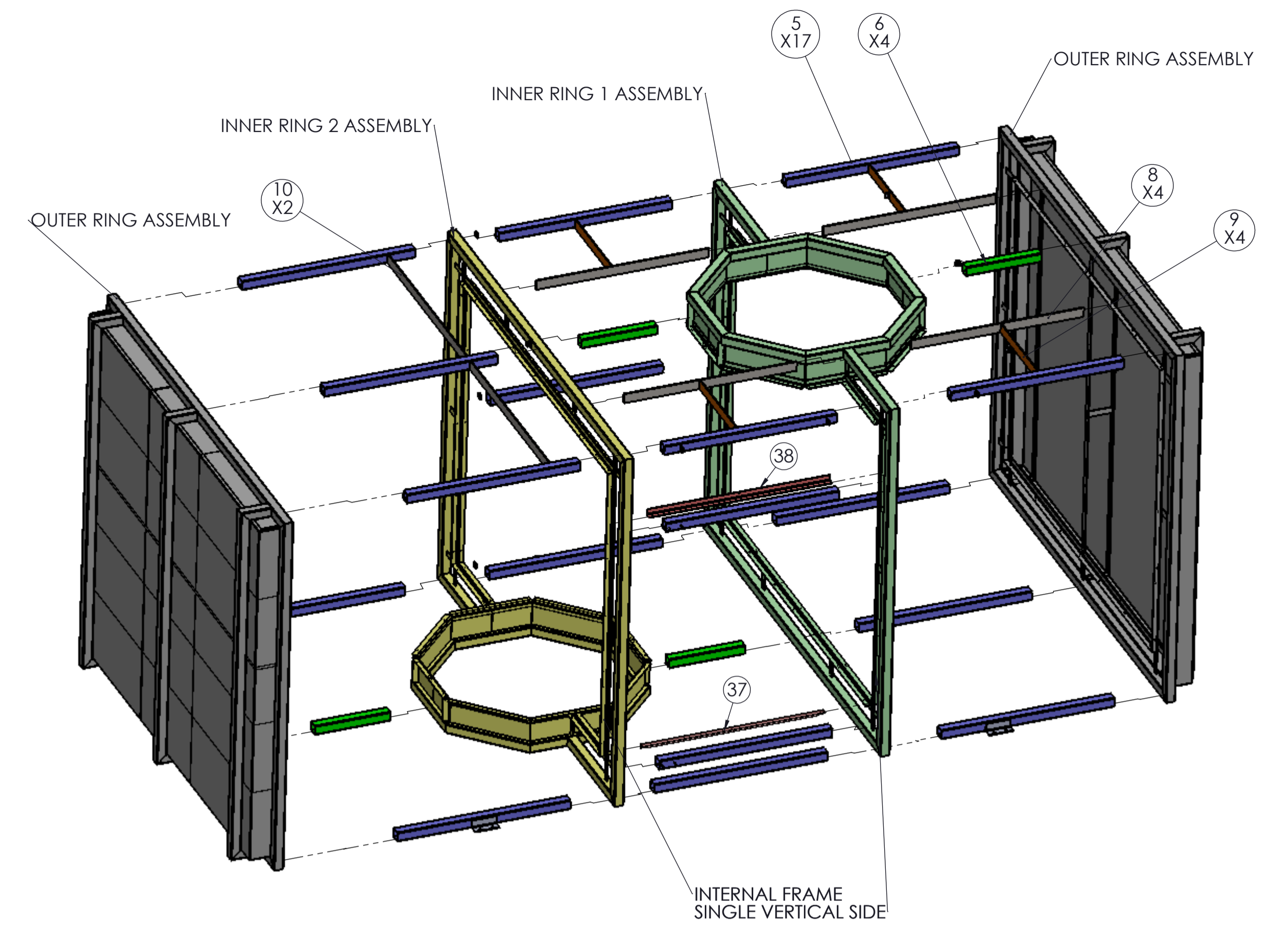
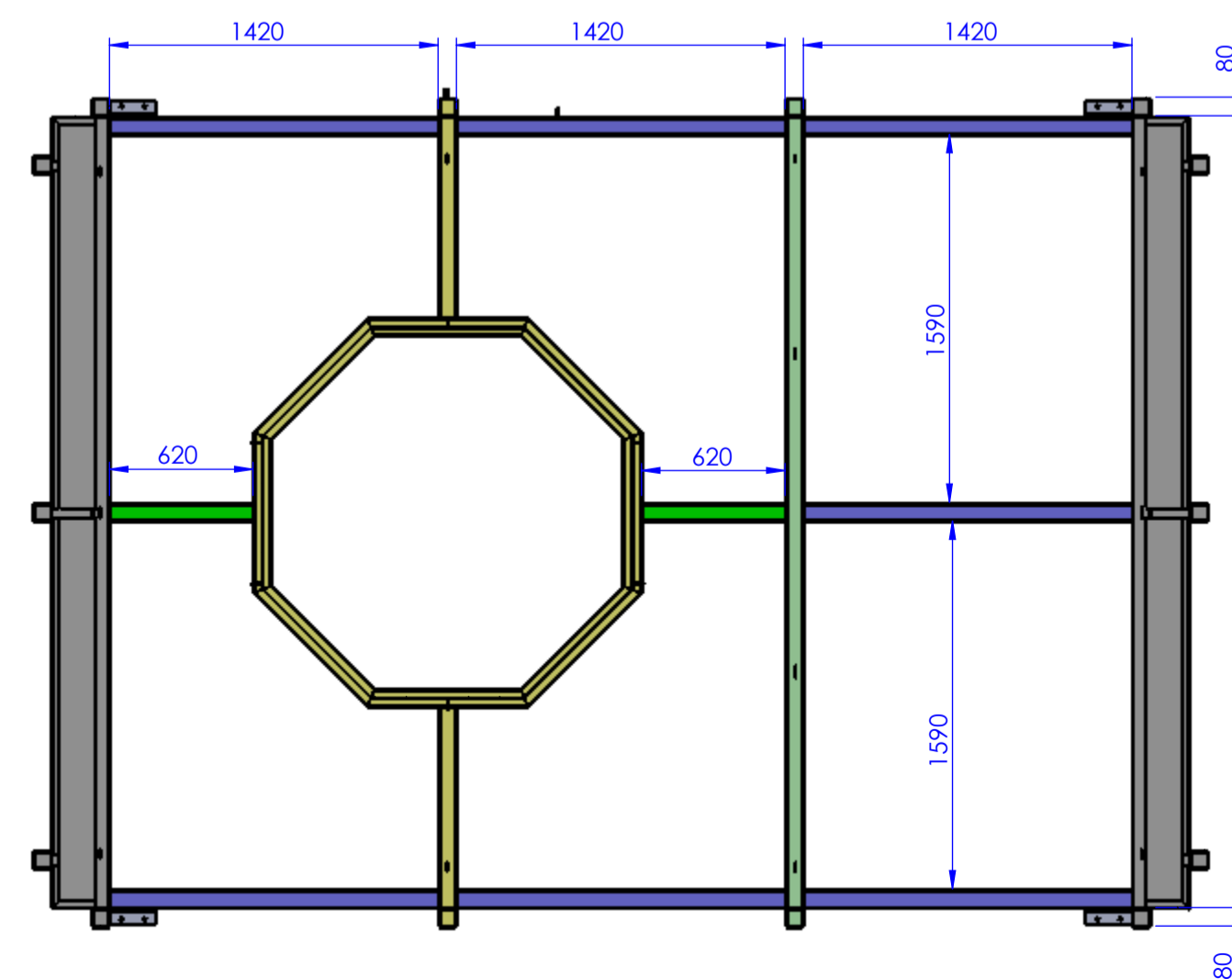

PLAN VIEW CLOSE UP ON DOOR AREA

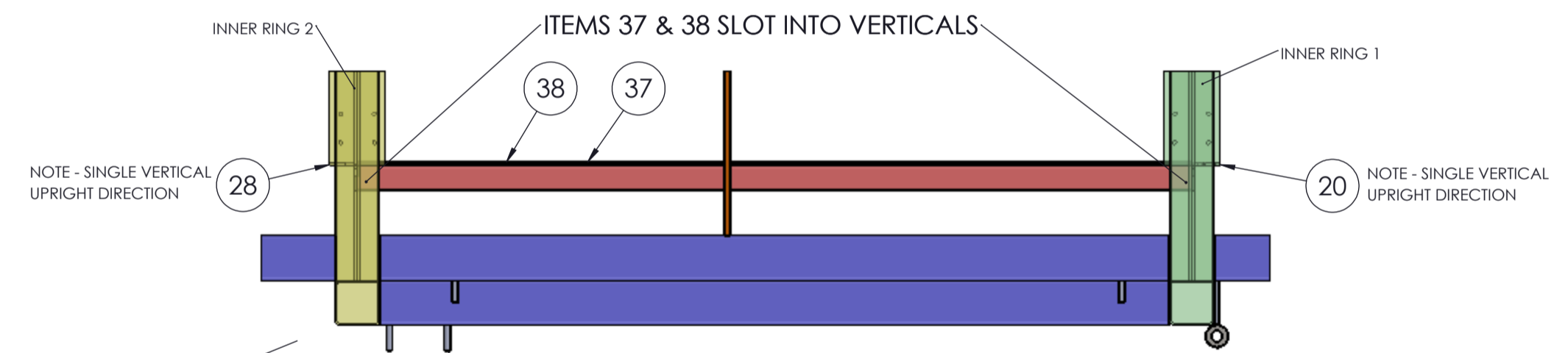

SEE DETAIL C-F

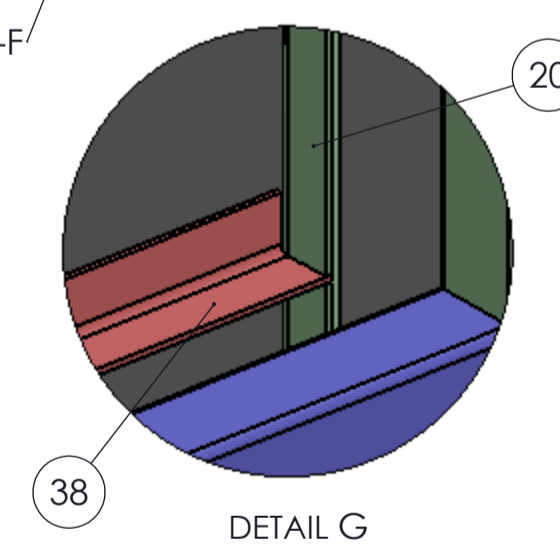

DETAIL G

ITEMS 37 & 38 FIT TO SLOTS IN ITEMS 20 & 28

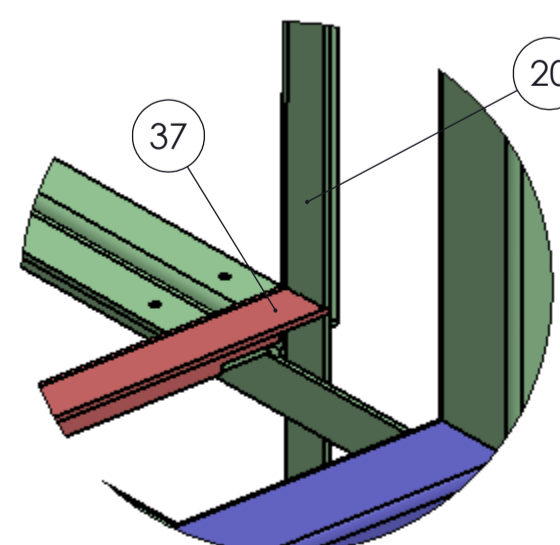

DETAIL H

APPROVAL STAMP

- De Burr all sharp edges
- All welds 6mm leg length fillets unless otherwise stated
- All equally sized box - box T Butt joints will have 2 x 6mm leg fillet welds & 2 x single bevel T butt welds unless otherwise stated
- All dimensions in mm unless otherwise stated
- This drawing remains the property of Noreside engineering
- This drawing may not be copied or passed to a third party without the prior written permission from Noreside engineering

| | | | |
|---------------|---------------|---------|---------|
| PROJECTION | 1ST ANGLE | WEIGHT | - |
| MATERIAL TYPE | STAINLESS 304 | QUALITY | CLASS 2 |
| FINISH | BLASTED | | |

NORESIDE
engineering limited
Hebron Industrial Estate
Kilkenny, Ireland
email: info@noreside.ie
Telephone: +353 (0) 56 7763966
Fax: +353 (0) 56 7763977

| | | | |
|--|------------|----------------|--|
| CUSTOMER, CLIENT: GLANBIA BALLYRAGGET | | | |
| DRAWING TITLE / PART DESCRIPTION: NOISE ATTENUATOR BOX - FRAME ASSEMBLY (1 of 6) | | | |
| DATE CREATED: 13-03-17 | SCALE: NTS | SHEET SIZE: A1 | |
| DRAWN BY: I. BUCKLEY | QUOTE No.: | 1828 | |
| CHECKED BY: | JOB No.: | 2655 | |
| ITEM/PART/ASSEMBLY No.: | SHEET No.: | 13 of 28 | |



| | | |
|-------------------------|----------|------------------------|
| DRAWING No. 2909-15-022 | | |
| REV No. | DATE | DESCRIPTION OF CHANGES |
| 0 | 13-03-17 | ORIGINAL |
| - | - | - |
| - | - | - |
| - | - | - |

| ITEM NO | QUANTITY | DESCRIPTION | MATERIAL | LENGTH | NOTES | PREWELD INSPECTION | POSTWELD INSPECTION |
|---------|----------|-----------------------|----------|--------|-----------|--------------------|---------------------|
| | 2 | OUTER RING ASSEMBLY | 304 | NA | | | |
| | 1 | INNER RING ASSEMBLY 1 | 304 | NA | | | |
| | 1 | INNER RING ASSEMBLY 2 | 304 | NA | | | |
| 5 | 17 | 80X80X5mm BOX | 304 | 1420 | CUT LIST | | |
| 6 | 4 | 80X80X5mm BOX | 304 | 620 | CUT LIST | | |
| 8 | 4 | 80X10 FLAT | 304 | 1420 | CUT LIST | | |
| 9 | 4 | 80X10 FLAT | 304 | 737 | CUT LIST | | |
| 10 | 2 | 80X10 FLAT | 304 | 1590 | CUT LIST | | |
| 37 | 1 | 5mm | 304 | 1510 | LASER CUT | | |
| 38 | 1 | 5mm | 304 | 1510 | LASER CUT | | |
| | 4 | 10X30 STUDS | 304 | 50 | | | |

OUTER SKINS - ALL SKINS FULLY WELDED

SECTION L-L
ROOF LEVEL OUTER SKINS

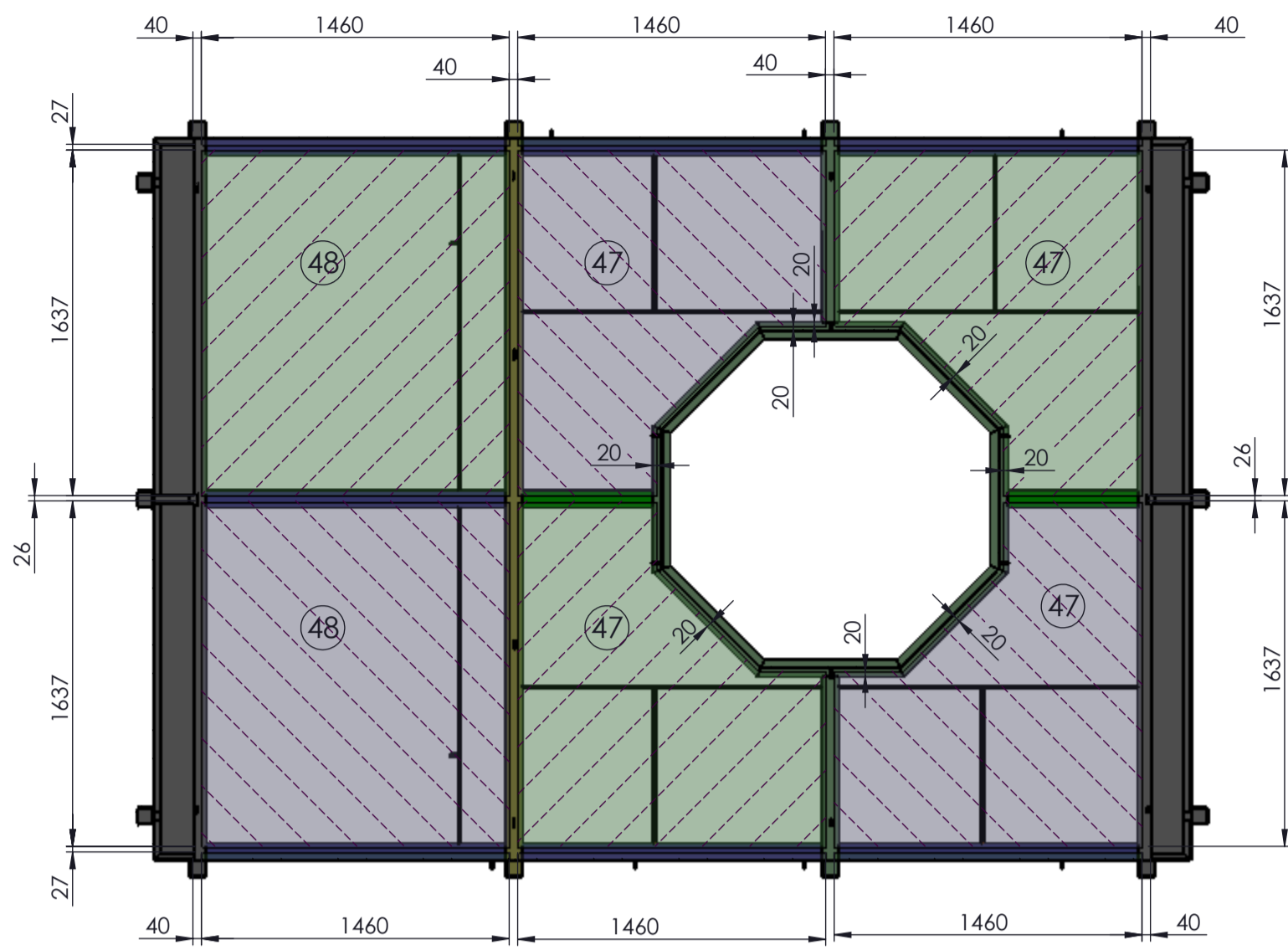

SECTION I-I
REAR WALL OUTER SKINS

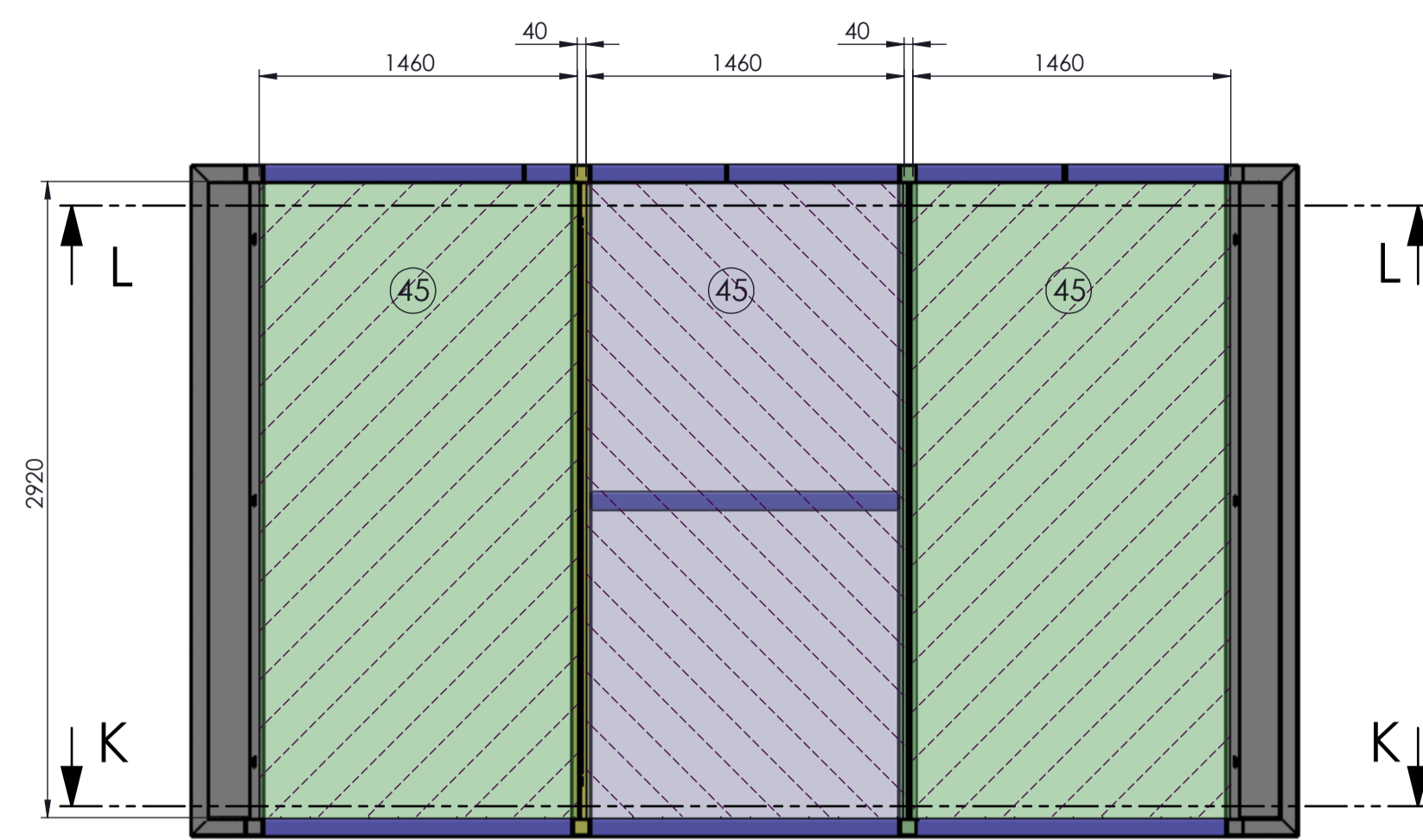

SECTION K-K
GROUND LEVEL OUTER SKINS

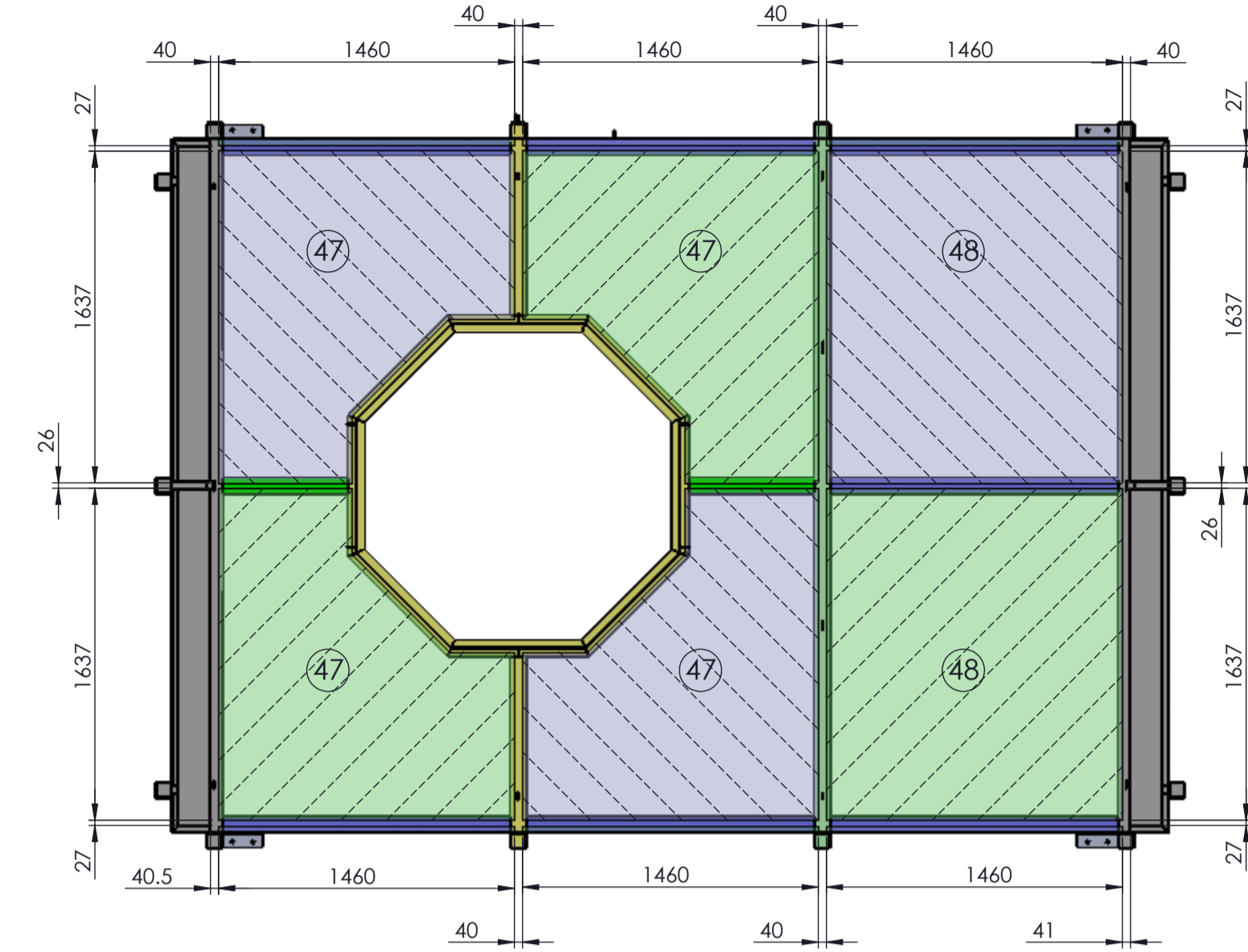

PLAN VIEW

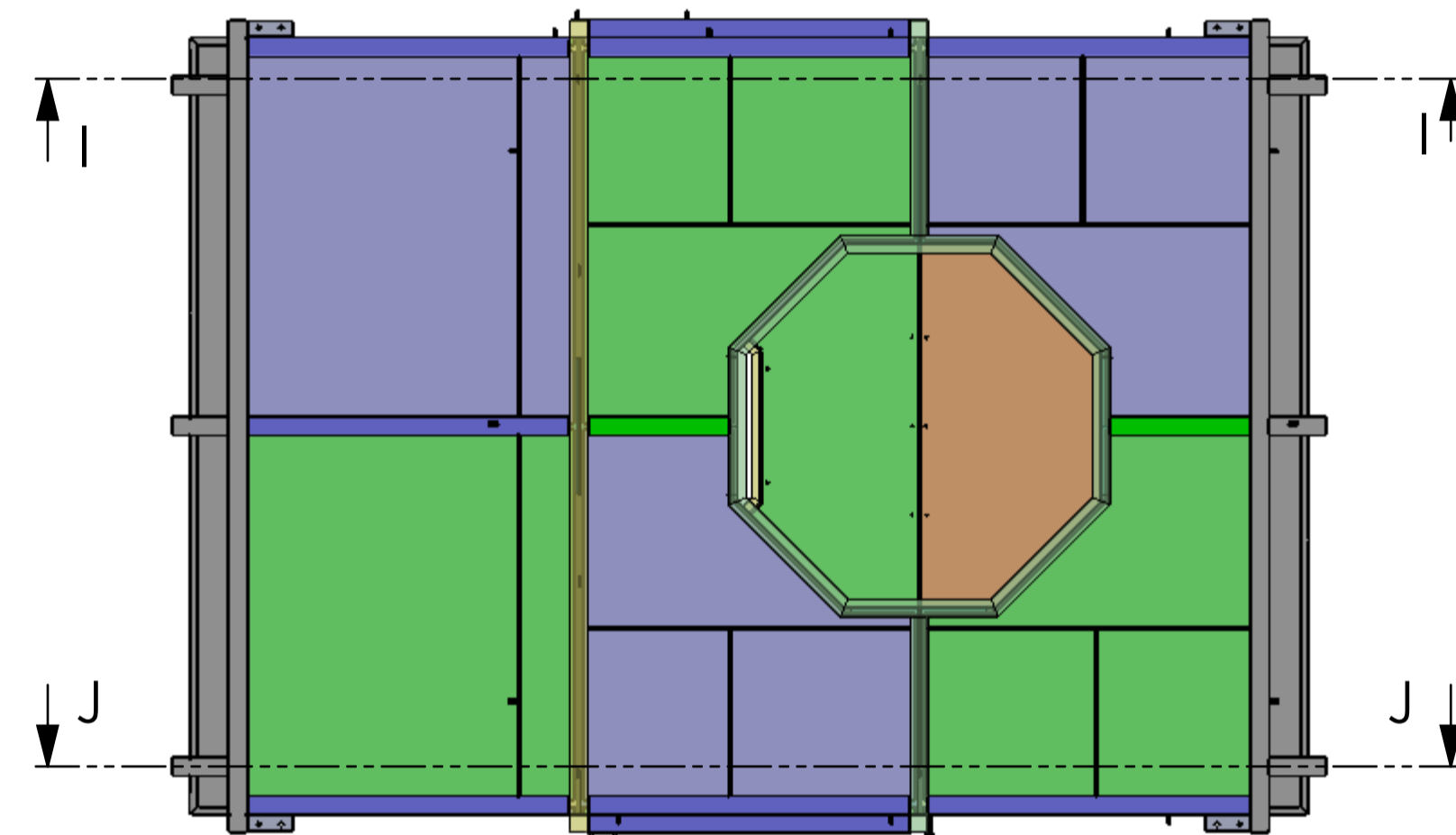

3D VIEW - TOP & FRONT

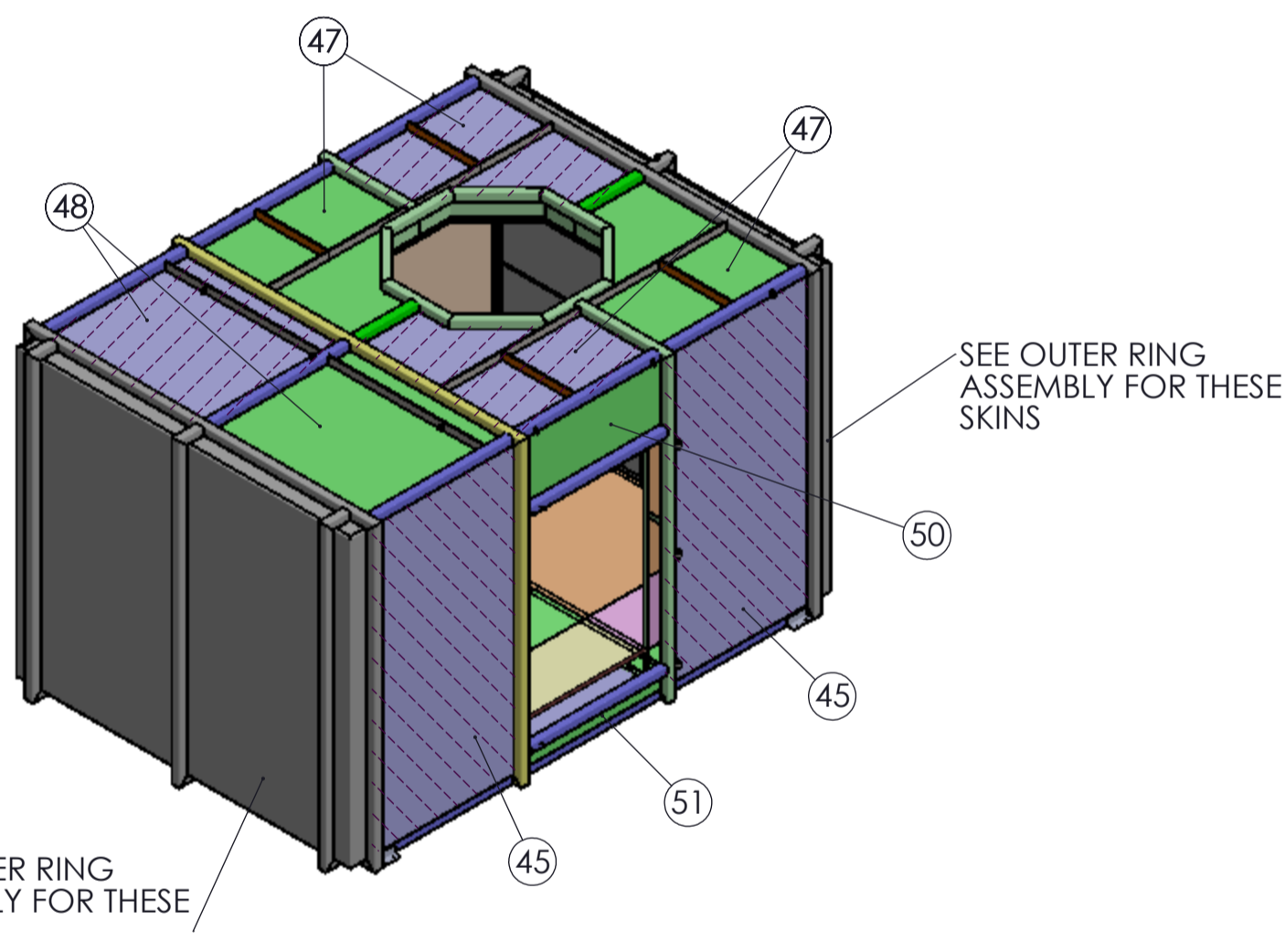

3D VIEW - REAR & BOTTOM

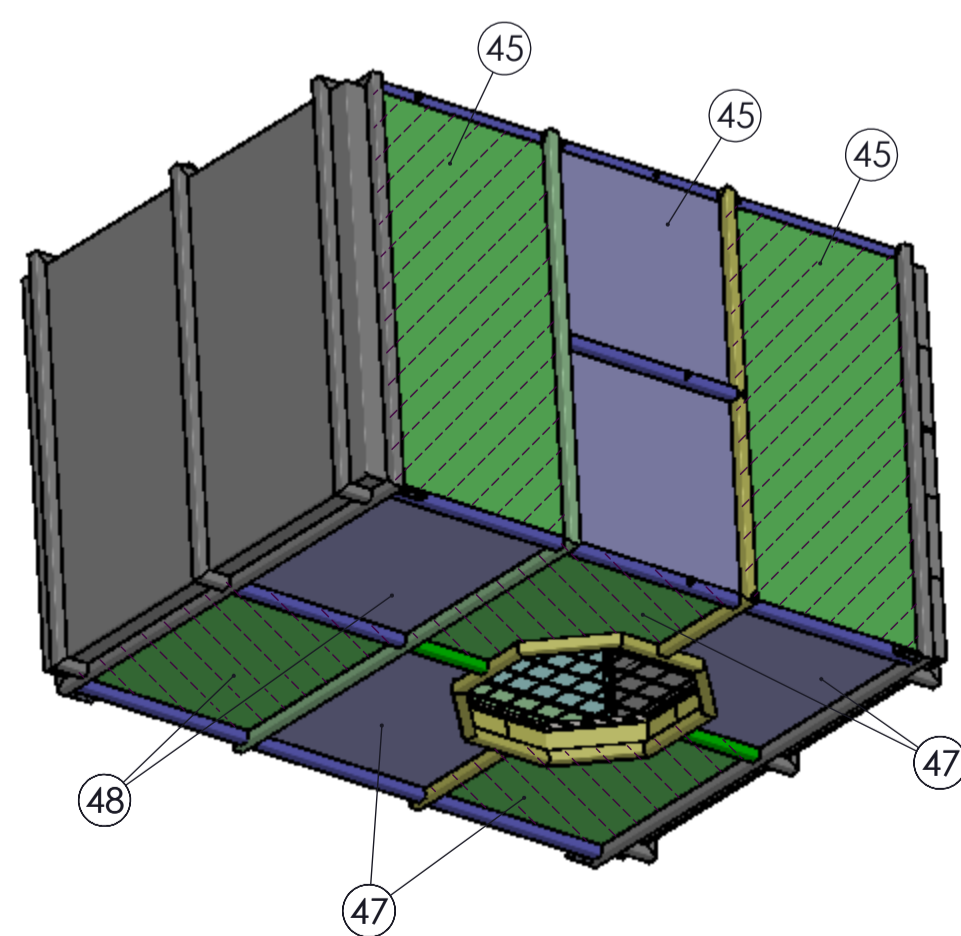

SECTION J-J
FRONT WALL OUTER SKINS

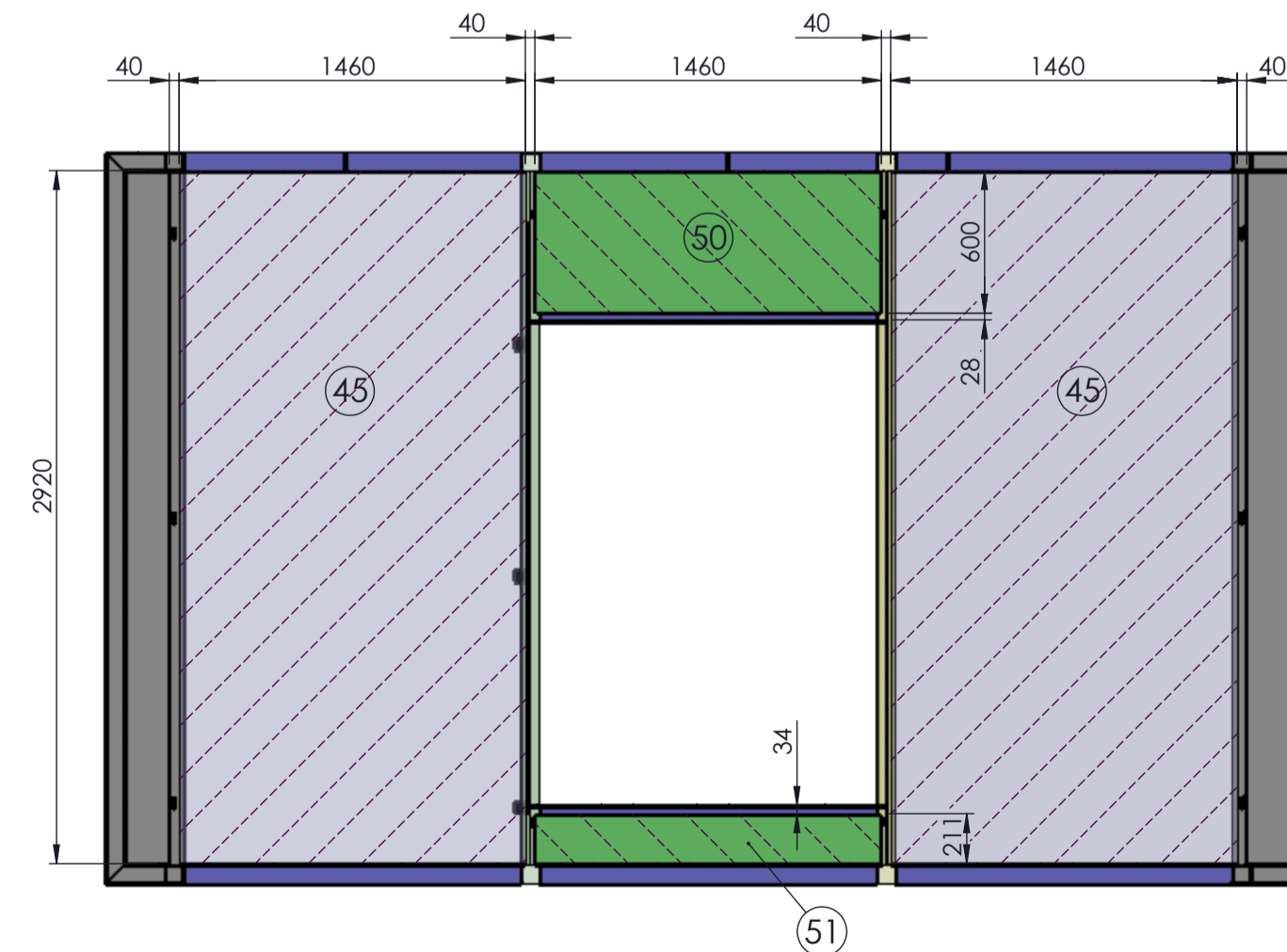

| ITEM NO | QUANTITY | DESCRIPTION | MATERIAL | LENGTH | NOTES | PREWELD INSPECTION | POST WELD INSPECTION |
|---------|----------|-------------|----------|-----------|-----------|--------------------|----------------------|
| 45 | 5 | 3mm | 304 | 2977X1460 | LASER CUT | | |
| 47 | 8 | 3mm | 304 | 1637X1460 | LASER CUT | | |
| 48 | 4 | 3mm | 304 | 1637X1460 | LASER CUT | | |
| 50 | 1 | 3mm | 304 | 628X1460 | LASER CUT | | |
| 51 | 1 | 3mm | 304 | 1460X239 | LASER CUT | | |

APPROVAL STAMP

- De Burr all sharp edges
- All welds 6mm leg length fillets unless otherwise stated
- All equally sized box - box T Butt joints will have 2 x 6mm leg fillet welds & 2 x single bevel T butt welds unless otherwise stated
- All dimensions in mm unless otherwise stated
- This drawing remains the property of Noreside engineering
- This drawing may not be copied or passed to a third party without the prior written permission from Noreside engineering

| | | | |
|---------------|---------------|---------|---------|
| PROJECTION | 1ST ANGLE | WEIGHT | - |
| MATERIAL TYPE | STAINLESS 304 | QUALITY | CLASS 2 |
| FINISH | BLASTED | | |

NORESIDE engineering limited
Hebron Industrial Estate
Kilkenny, Ireland
email: info@noreside.ie
Telephone: +353 (0) 56 7763966
Fax: +353 (0) 56 7763977

CUSTOMER, CLIENT: **GLANBIA BALLYRAGGET**

DRAWING TITLE / PART DESCRIPTION: **NOISE ATTENUATOR BOX - FRAME ASSEMBLY (OUTER SKINS) (2 of 6)**

| | | | | | |
|--------------|------------|-----------|----------|------------|------|
| DATE CREATED | 13-03-17 | SCALE | NTS | SHEET SIZE | A1 |
| DRAWN BY | I. BUCKLEY | QUOTE No. | 1828 | JOB No. | 2655 |
| CHECKED BY | | SHEET No. | 14 of 28 | | |

| | | |
|---------|----------|------------------------|
| REV No. | DATE | DESCRIPTION OF CHANGES |
| 0 | 13-03-17 | ORIGINAL |
| - | - | - |
| - | - | - |
| - | - | - |



DOOR FRAME PANELS - FITTING

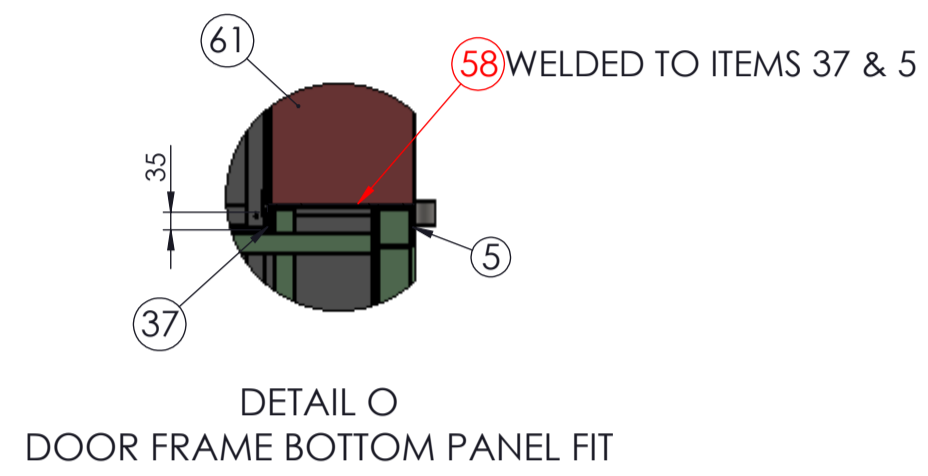
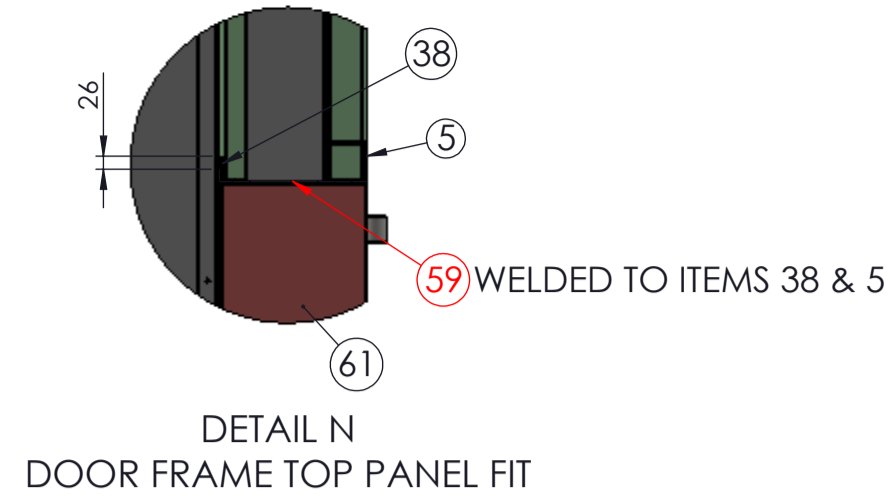
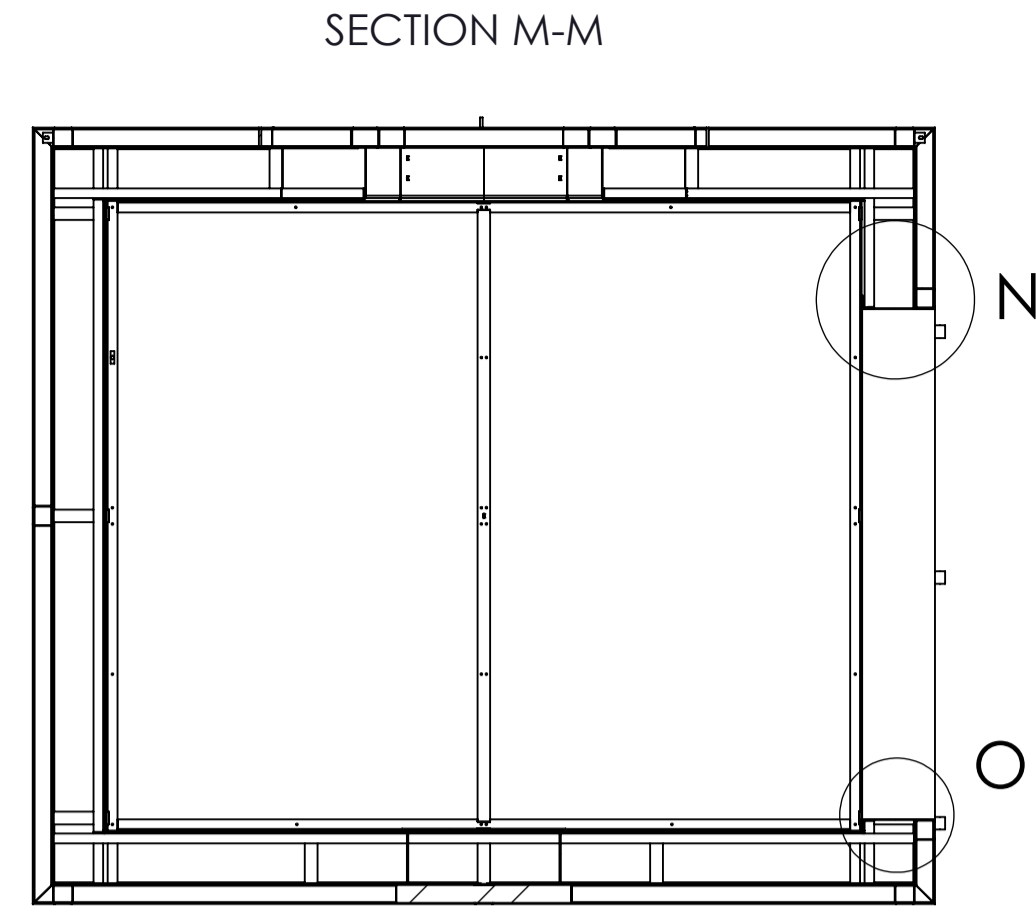
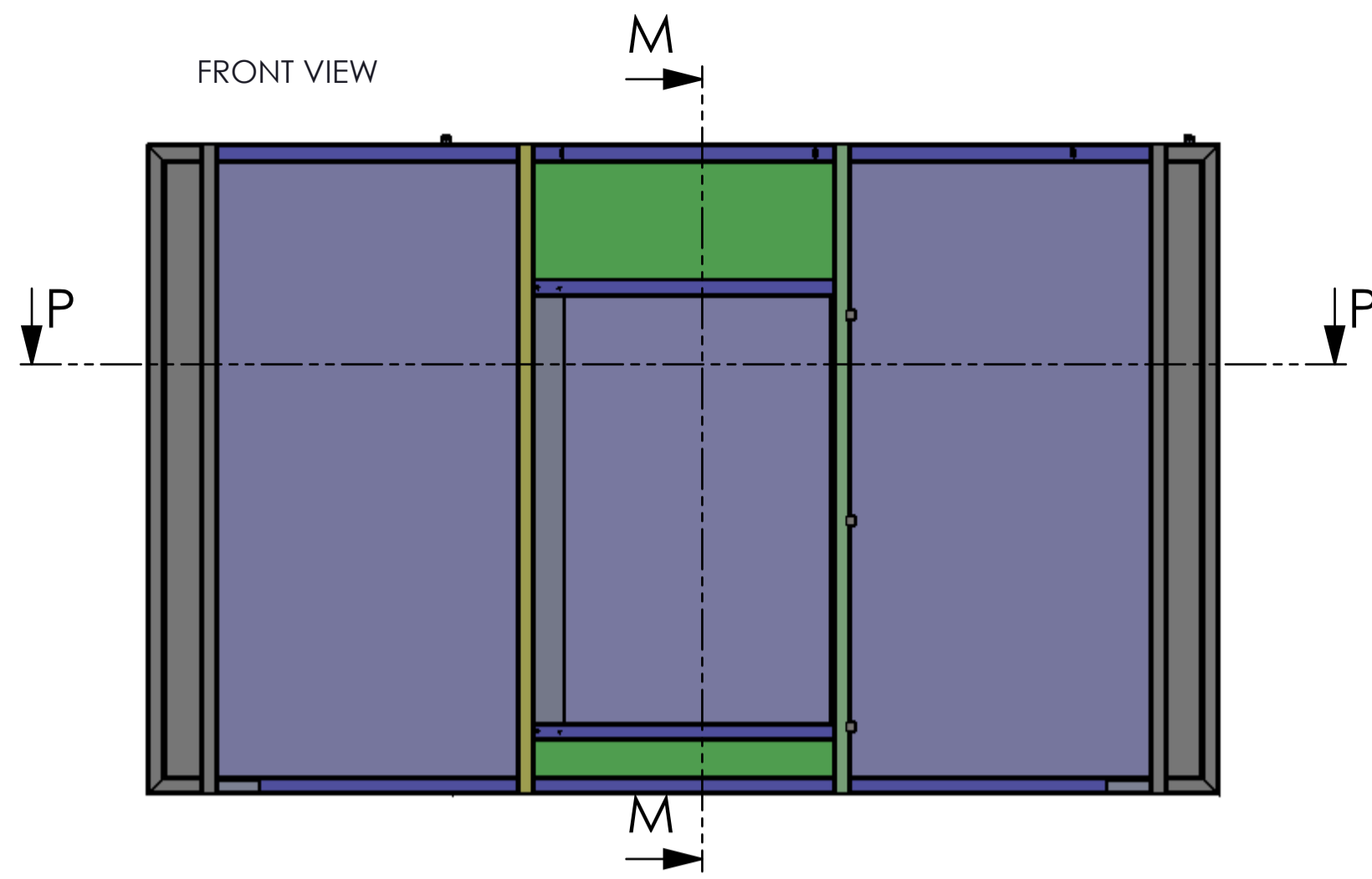

SECTION P-P

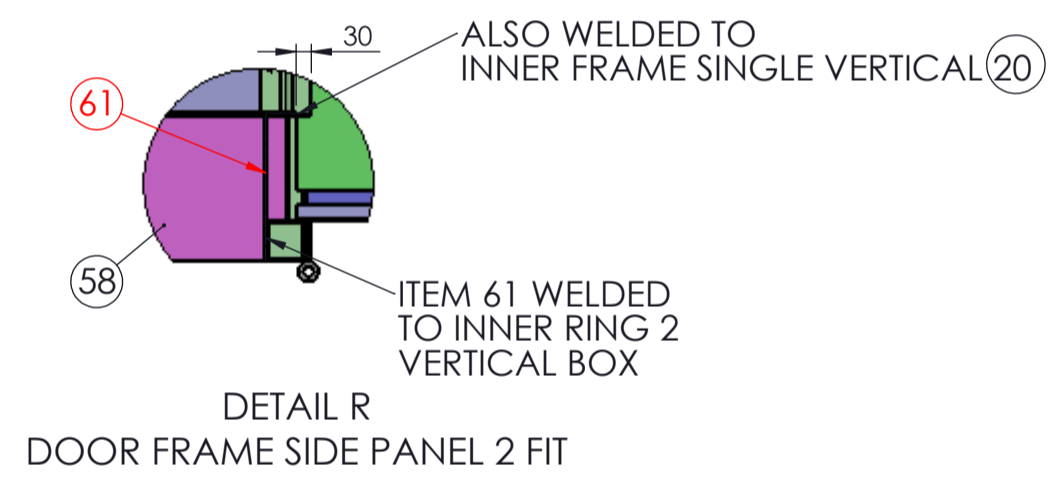
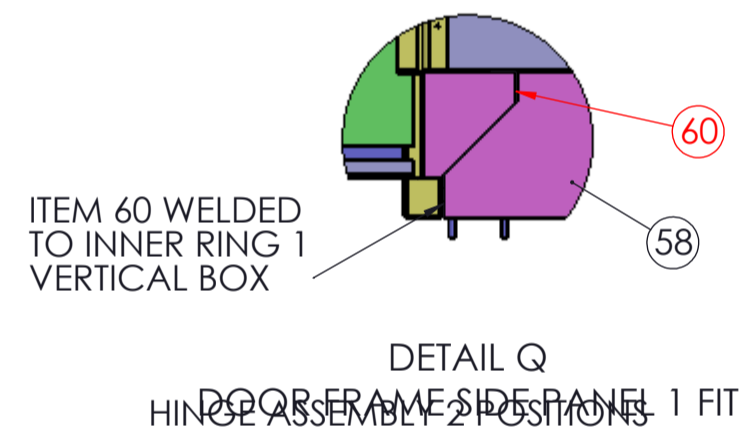
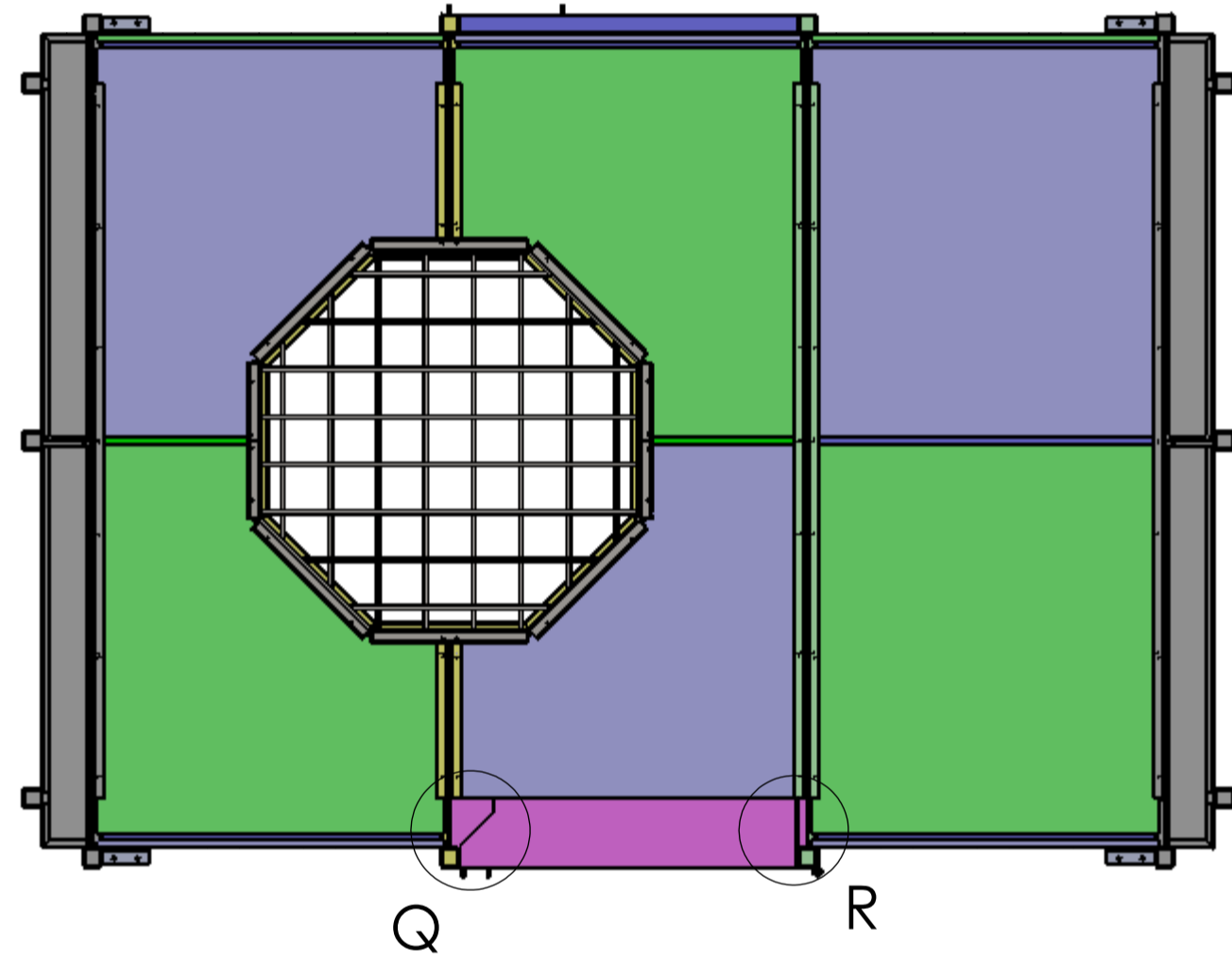

EXPLODED ASSEMBLY

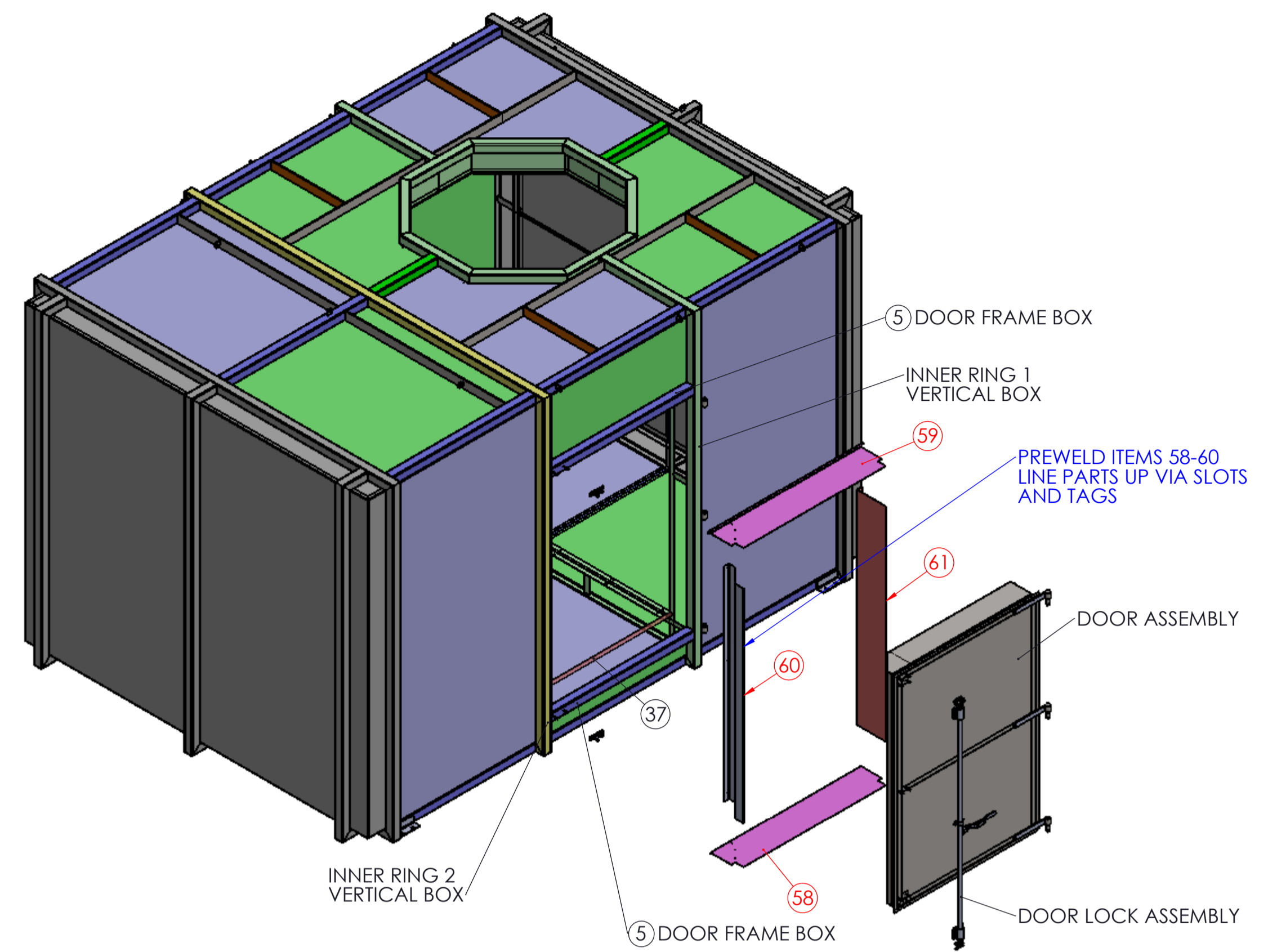

| ITEM NO | QUANTITY | DESCRIPTION | MATERIAL | LENGTH | NOTES | PREWELD INSPECTION | POST WELD INSPECTION |
|---------|----------|-------------|----------|----------|-----------|--------------------|----------------------|
| 58 | 1 | 2mm | 304 | 1500X307 | LASER CUT | | |
| 59 | 1 | 2mm | 304 | 1548X315 | LASER CUT | | |
| 60 | 1 | 2mm | 304 | 2025X399 | LASER CUT | | |
| 61 | 1 | 2mm | 304 | 2025X351 | LASER CUT | | |

DOOR FITTING DIMENSIONS

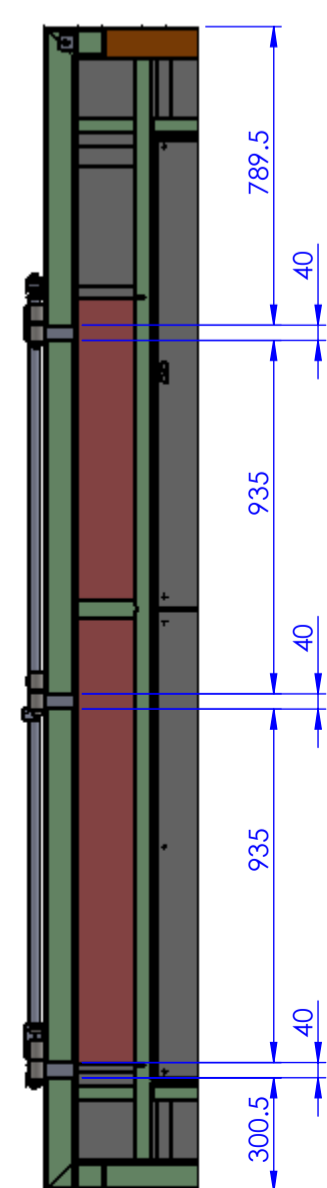
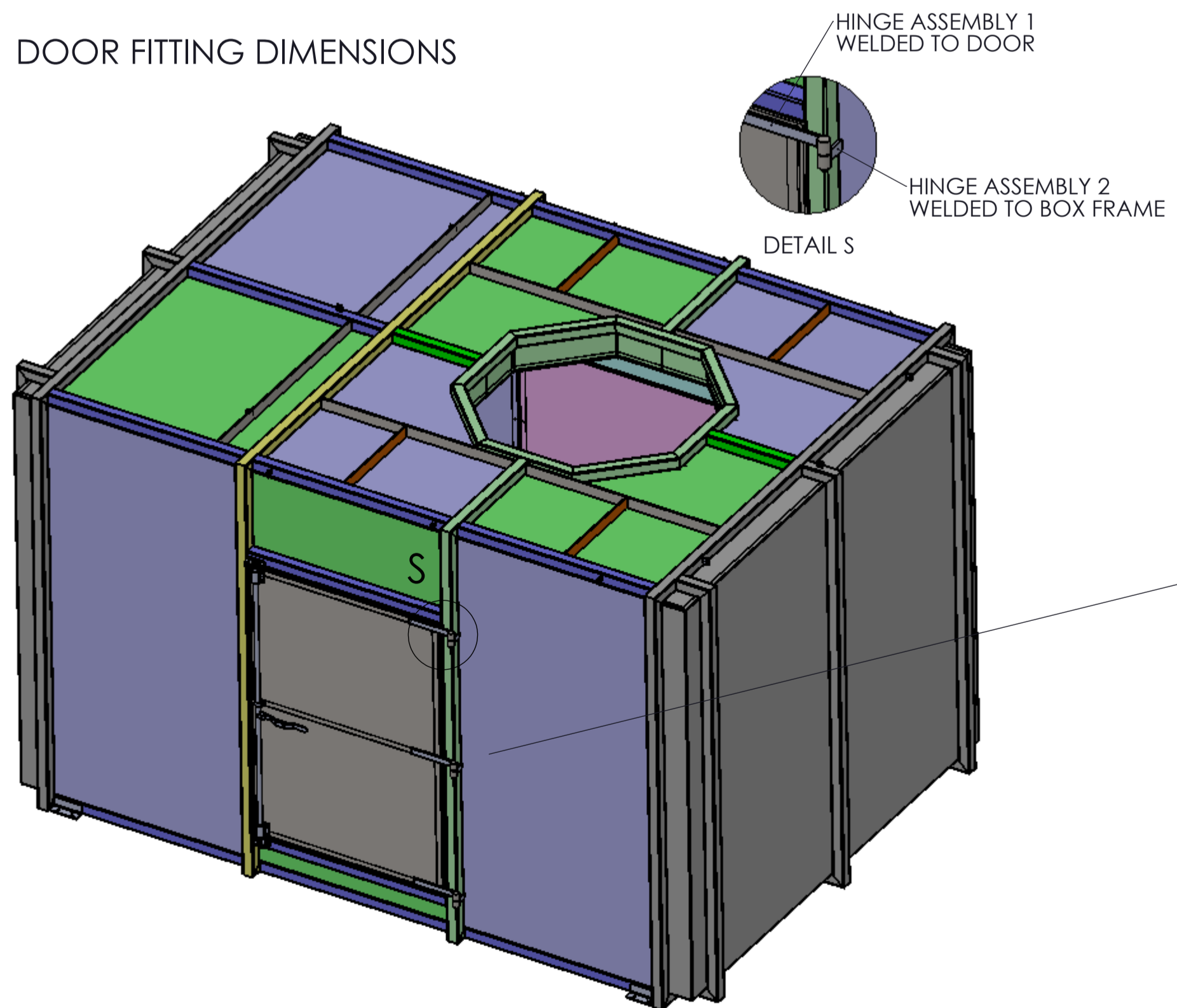

DOOR FIT MEASUREMENTS

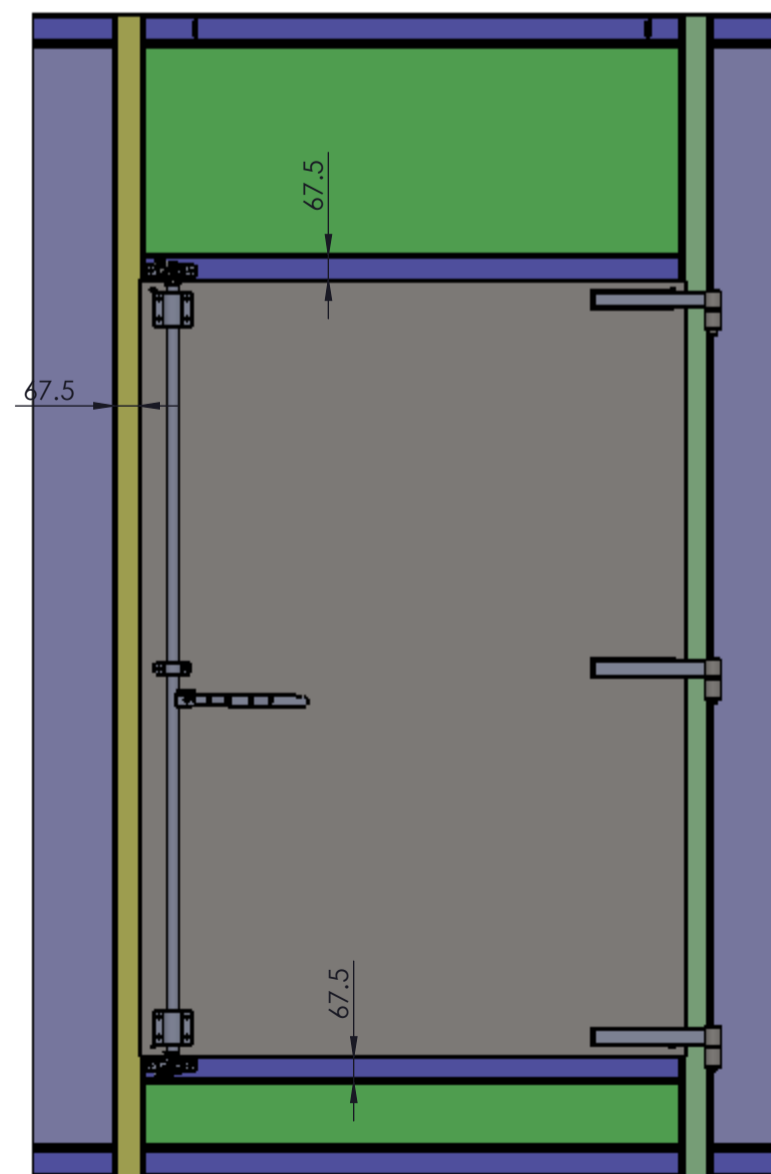

GAPS BETWEEN DOOR & DOOR FRAME

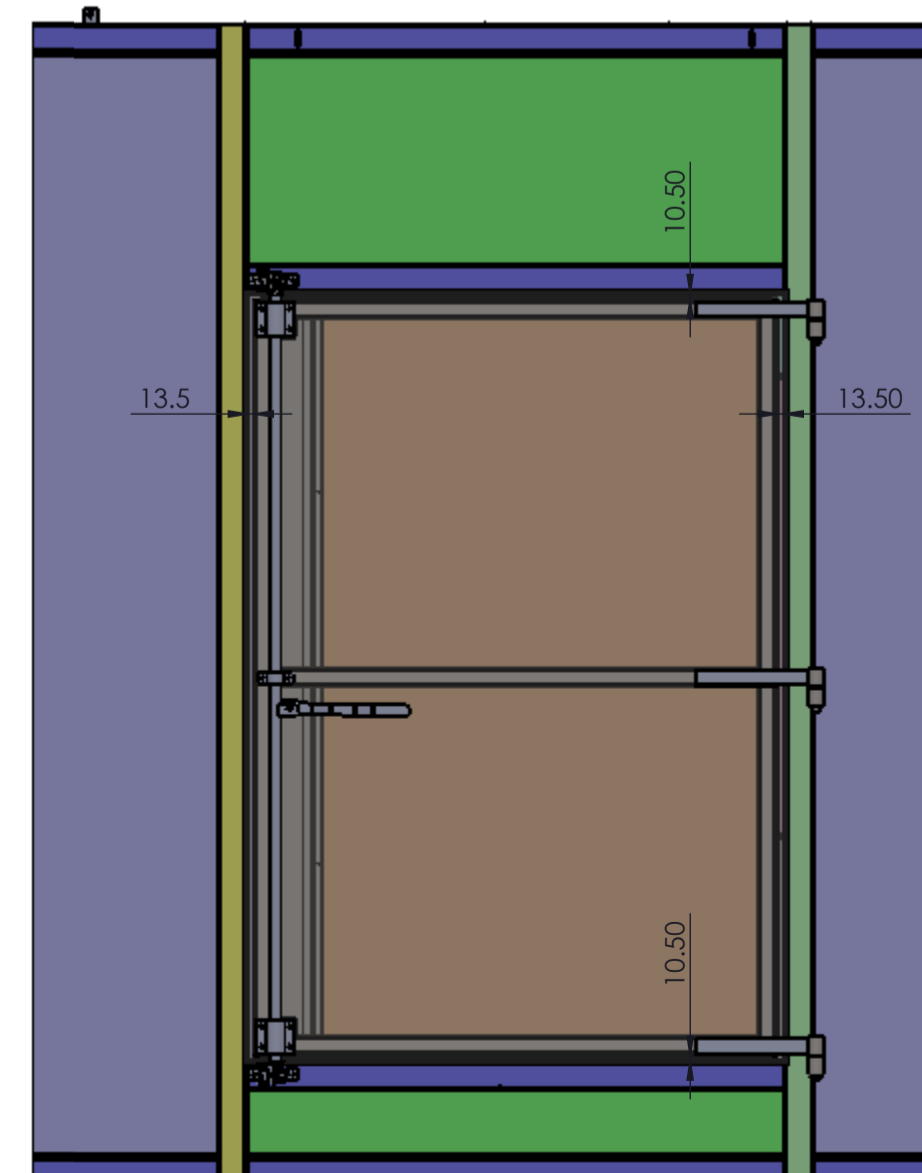

APPROVAL STAMP

- De Burr all sharp edges
- All welds 6mm leg length fillets unless otherwise stated
- All equally sized box - box T Butt joints will have 2 x 6mm leg fillet welds & 2 x single bevel T butt welds unless otherwise stated
- All dimensions in mm unless otherwise stated
- This drawing remains the property of Noreside engineering
- This drawing may not be copied or passed to a third party without the prior written permission from Noreside engineering

| | | | |
|---------------|---------------|---------|---------|
| PROJECTION | 1ST ANGLE | WEIGHT | - |
| MATERIAL TYPE | STAINLESS 304 | QUALITY | CLASS 2 |
| FINISH | BLASTED | | |



| | | | |
|---|------------|-----------|----------|
| CUSTOMER, CLIENT GLANBIA BALLYRAGGET | | | |
| DRAWING TITLE / PART DESCRIPTION NOISE ATTENUATOR BOX - FRAME ASSEMBLY (DOOR FRAME + DOOR FIT) (3 of 6) | | | |
| DATE CREATED | 13-03-17 | SCALE | NTS |
| DRAWN BY | I. BUCKLEY | QUOTE No. | 1828 |
| CHECKED BY | | JOB No. | 2655 |
| ITEM/PART/ASSEMBLY No. | | SHEET No. | 15 of 28 |



| | | |
|-------------|----------|------------------------|
| DRAWING No. | | 2909-15-024 |
| REV No. | DATE | DESCRIPTION OF CHANGES |
| 0 | 13-03-17 | ORIGINAL |
| - | - | - |
| - | - | - |
| - | - | - |

STEP 1 - FRAME ASSEMBLY

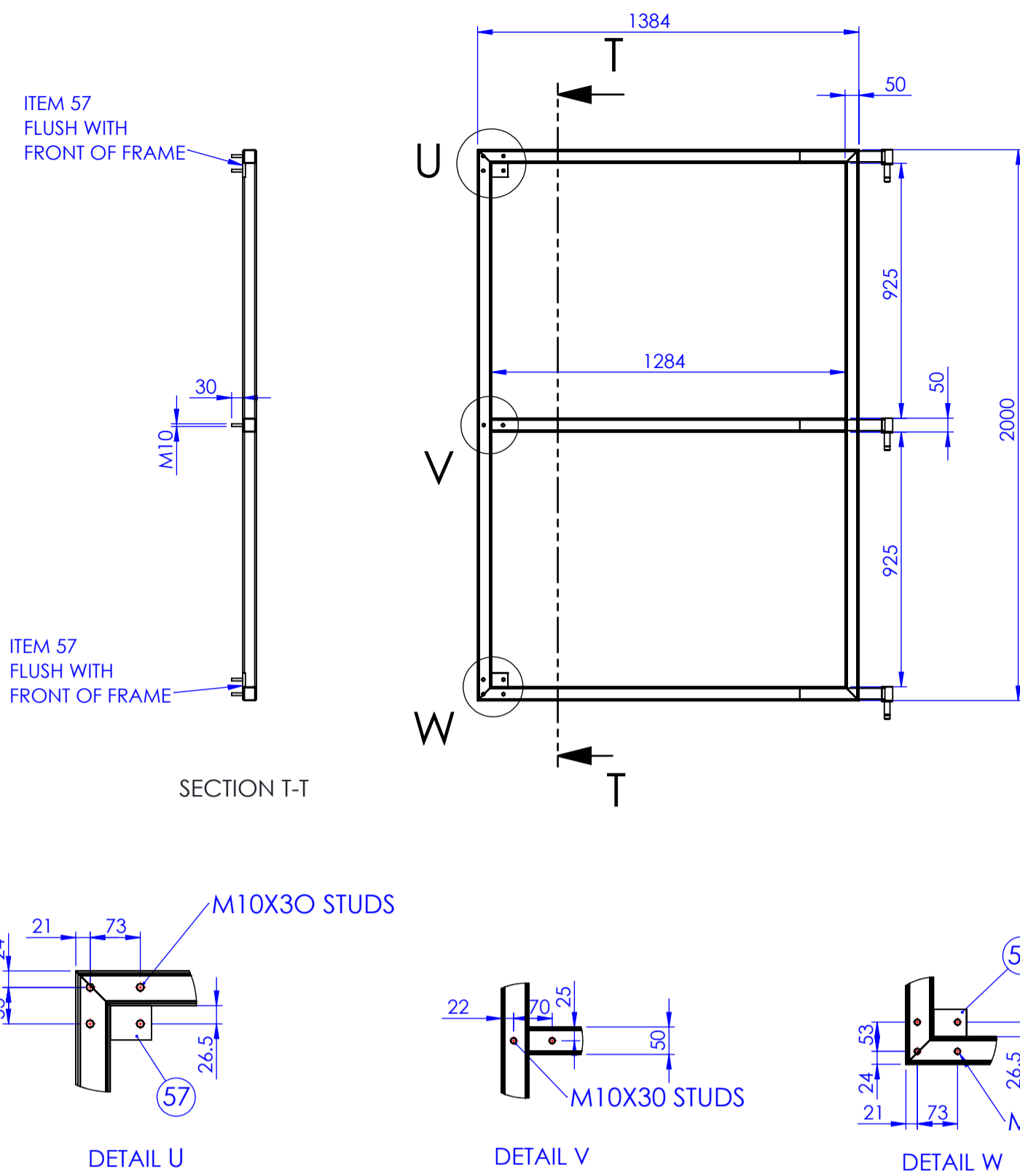

STEP 3 - INSULATED PANELS & PERFORATED PANEL FIT

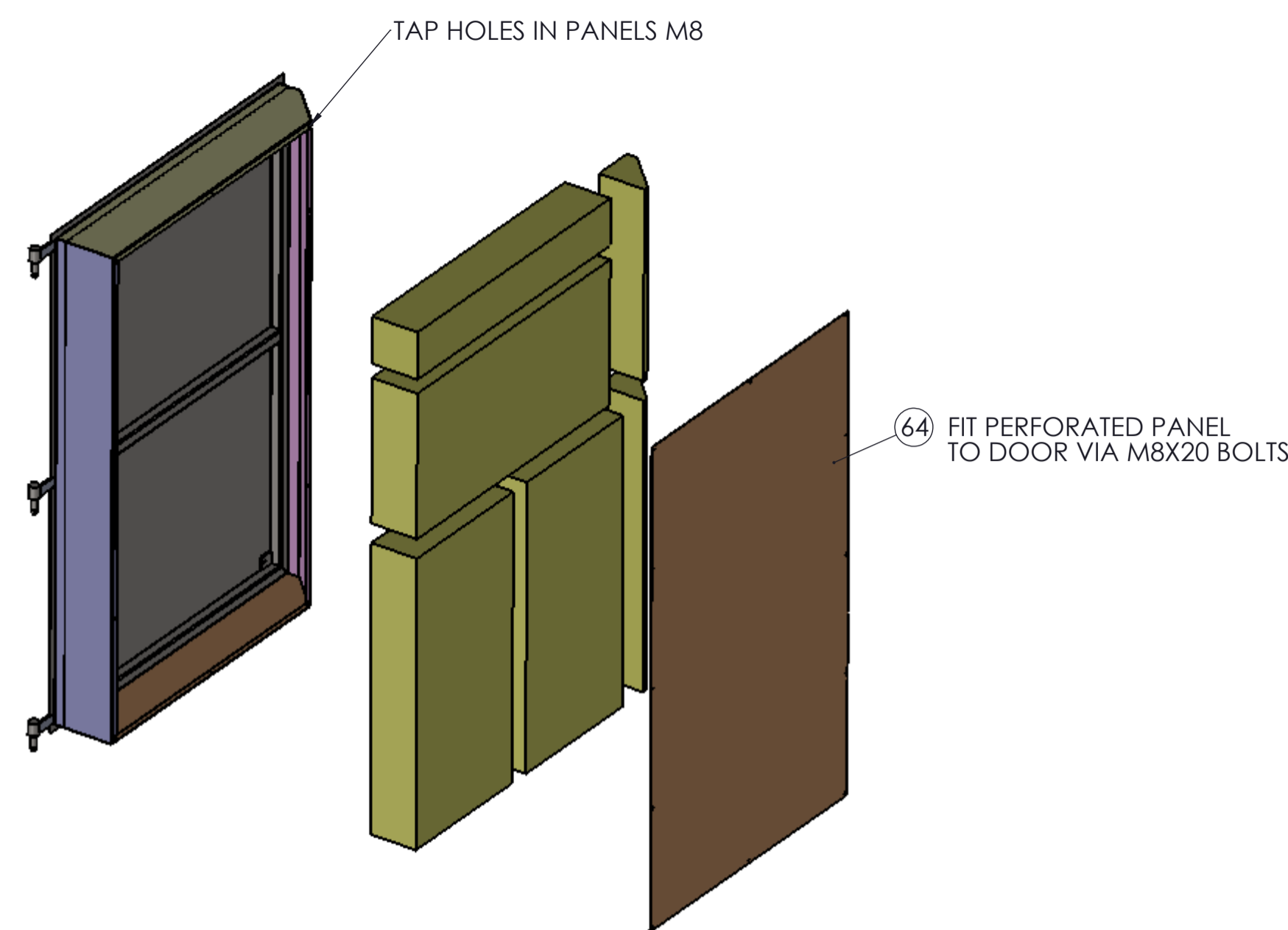

EXPLODED ASSEMBLY

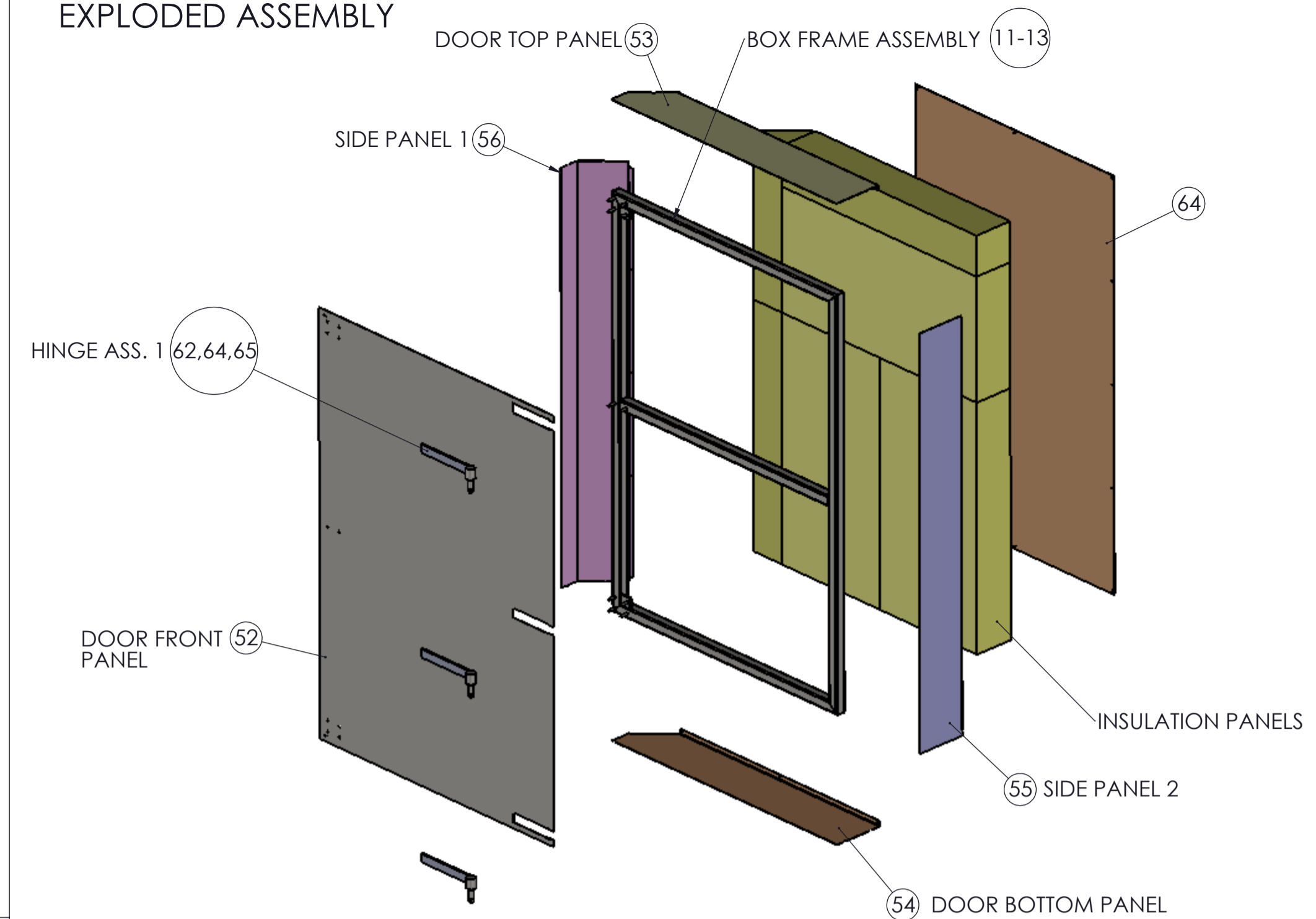

FRONT VIEW

REAR VIEW

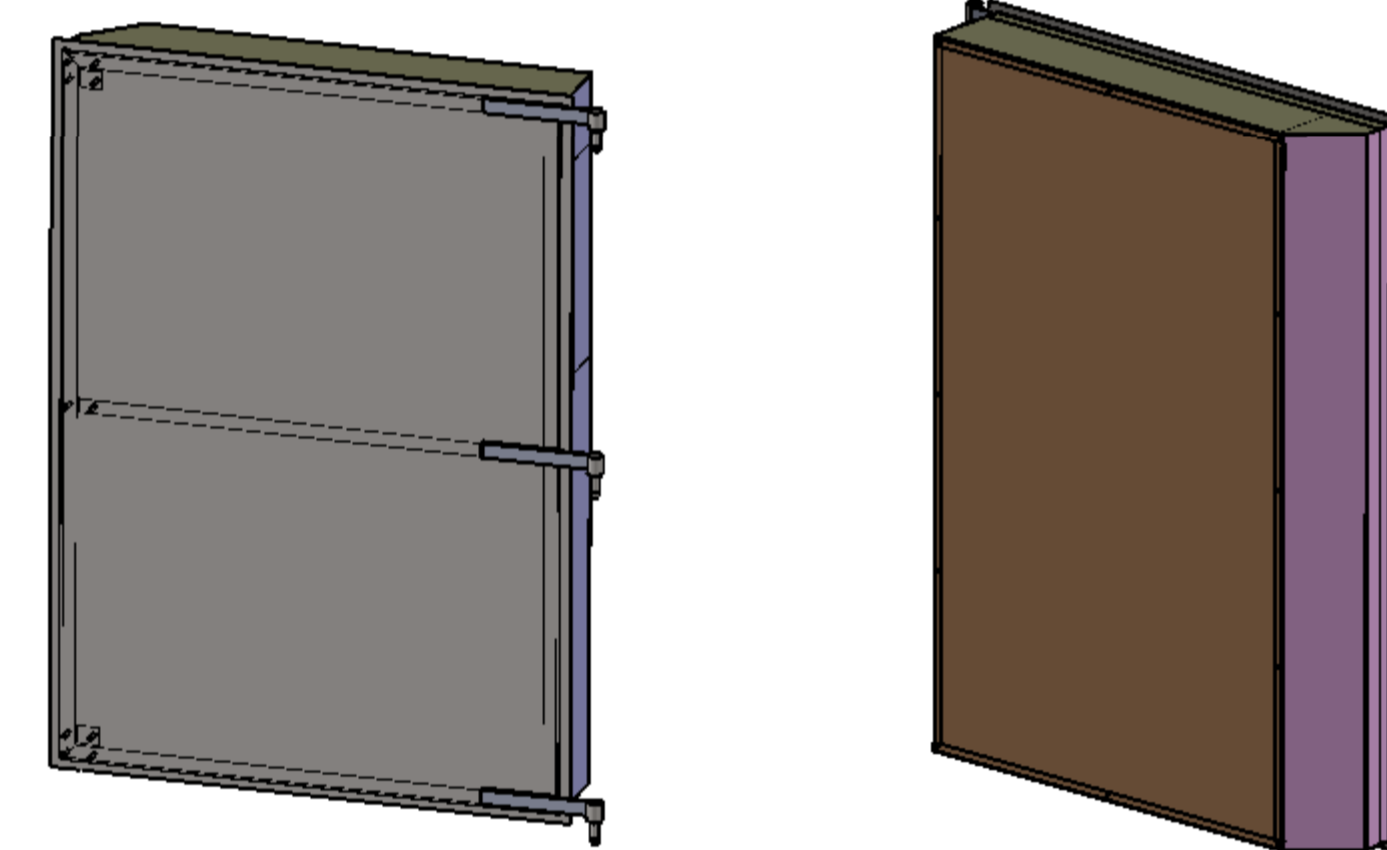

STEP 2 - PANEL ASSEMBLY

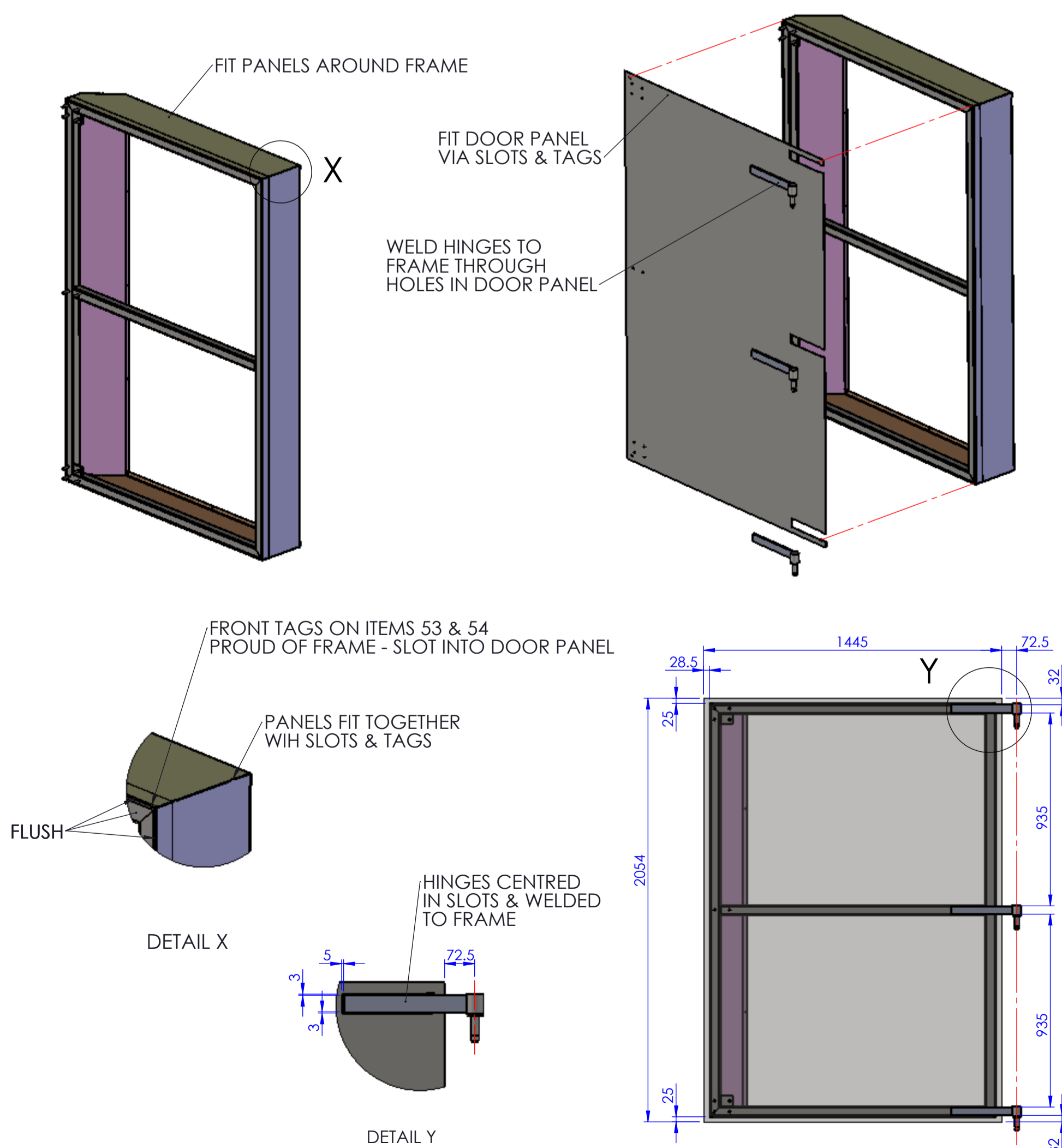

HINGE ASSEMBLY 1
QUANTITY: 3 (FIT TO DOOR)

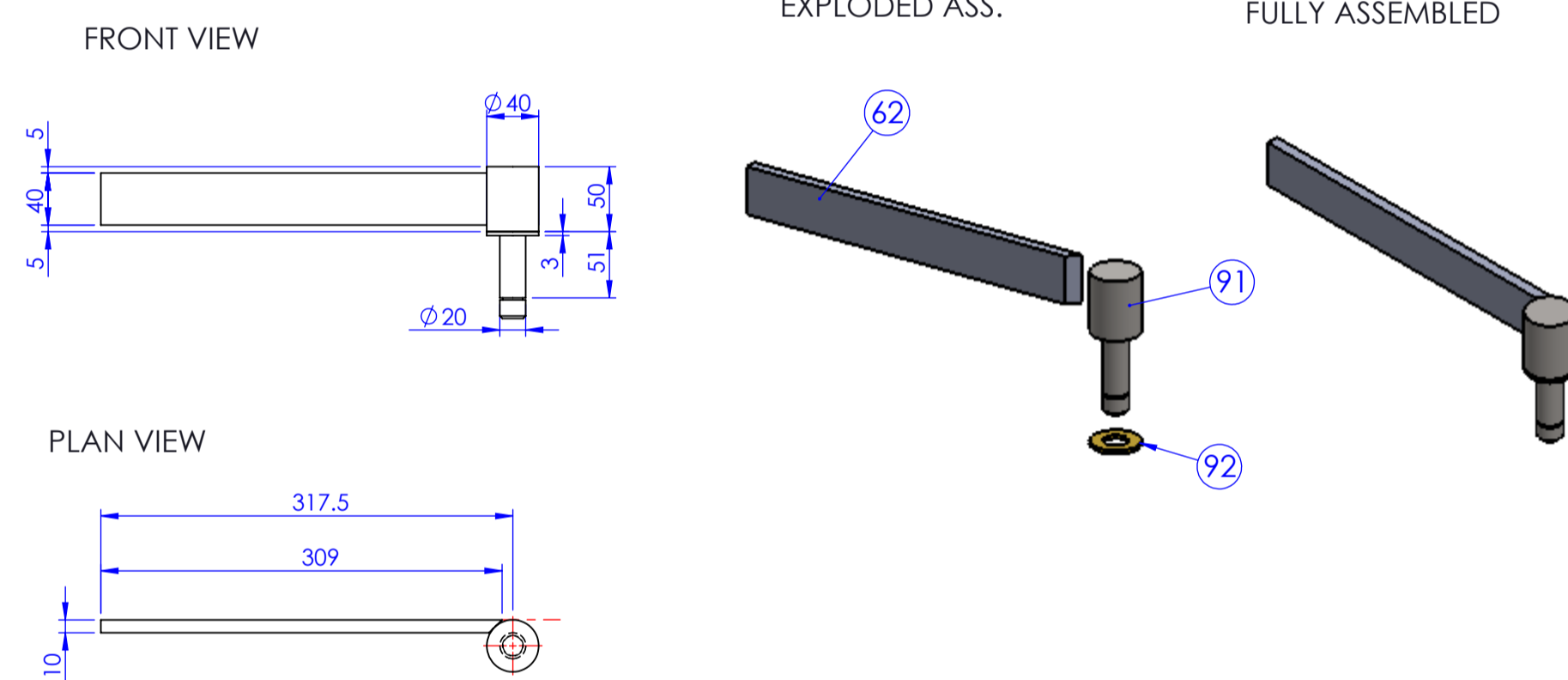

HINGE ASSEMBLY 2
QUANTITY: 3 (FIT TO BOX FRAME)

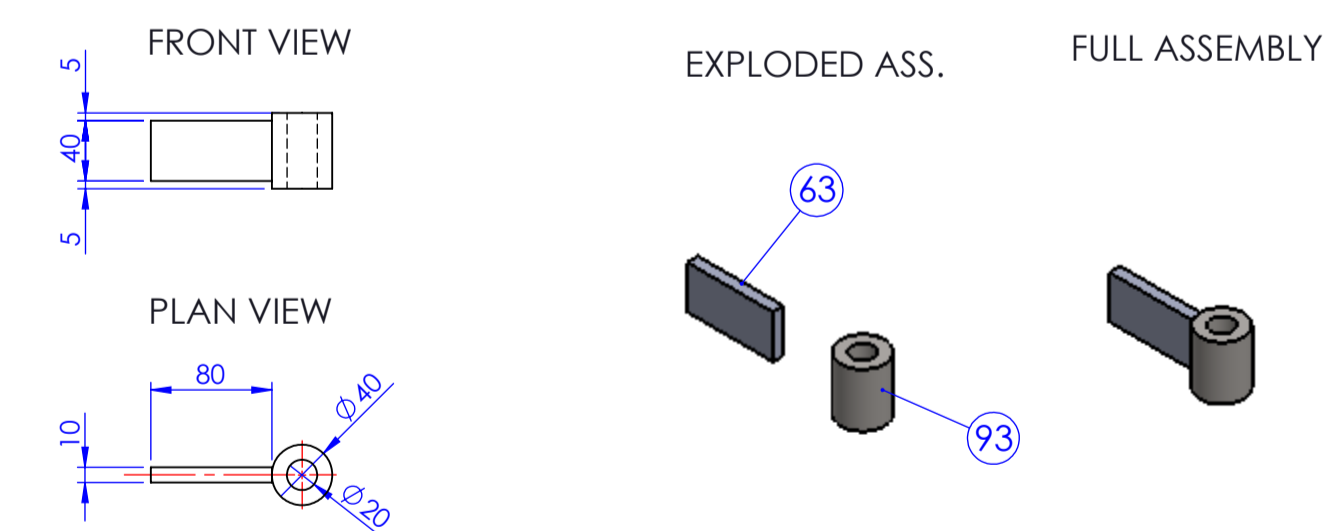

| ITEM NO | QUANTITY | DESCRIPTION | LENGTH | MATERIAL | NOTES | PREWELD INSPECTION | POST WELD INSPECTION |
|---------|----------|----------------------|-----------|----------|--------------|--------------------|----------------------|
| 11 | 2 | 50X50X5mm BOX | 1371 | 304 | CUT LIST | | |
| 12 | 1 | 50X50X5mm BOX | 1284 | 304 | CUT LIST | | |
| 13 | 2 | 50X50X5mm BOX | 2000 | 304 | CUT LIST | | |
| 52 | 1 | 3mm | 2054X1445 | 304 | LASER CUT | | |
| 53 | 1 | 2mm | 1388X279 | 304 | LASER CUT | | |
| 54 | 1 | 2mm | 1388X279 | 304 | LASER CUT | | |
| 55 | 1 | 2mm | 1950X277 | 304 | LASER CUT | | |
| 56 | 1 | 2mm | 2000X343 | 304 | LASER CUT | | |
| 57 | 2 | 10mm | 50X60 | 304 | LASER CUT | | |
| 62 | 3 | 40X10mm FLAT | 309 | 304 | CUT LIST | | |
| 63 | 3 | 40X10mm FLAT | 80 | 304 | CUT LIST | | |
| 64 | 1 | 2mm PERFORATED | 1994X1223 | 304 | IN HOUSE | | |
| 91 | 3 | HINGE | | 304 | MACHINE SHOP | | |
| 92 | 3 | HINGE | | 304 | MACHINE SHOP | | |
| 93 | 3 | HINGE | | 304 | MACHINE SHOP | | |
| 95 | 3 | STD INSULATION PANEL | 1200X600 | | SUPPLIED | | |
| | 1 | INSULATION PANEL | | | SUPPLIED | | |
| | 1 | INSULATION PANEL | | | SUPPLIED | | |
| | 1 | INSULATION PANEL | | | SUPPLIED | | |
| | 1 | INSULATION PANEL | | | SUPPLIED | | |
| | 1 | INSULATION PANEL | | | SUPPLIED | | |
| | 10 | M10X30 STUDS | 50 | 304 | | | |

APPROVAL STAMP

| | | | | |
|--|------------|-----------|---------------|---------------|
| <ul style="list-style-type: none"> - De Burr all sharp edges - All welds 6mm leg length fillets unless otherwise stated - All equally sized box - box T Butt joints will have 2 x 6mm leg fillet welds & 2 x single bevel T butt welds unless otherwise stated - All dimensions in mm unless otherwise stated - This drawing remains the property of Noreside engineering - This drawing may not be copied or passed to a third party without the prior written permission from Noreside engineering | PROJECTION | 1ST ANGLE | WEIGHT | - |
| | | | MATERIAL TYPE | STAINLESS 304 |
| | | QUALITY | CLASS 2 | |
| | | FINISH | BLASTED | |

NORESIDE engineering limited
Hebron Industrial Estate
Kilkenny, Ireland
email: info@noreside.ie
Telephone: +353 (0) 56 7763966
Fax: +353 (0) 56 7763977

CUSTOMER, CLIENT: **GLANBIA BALLYRAGGET**

DRAWING TITLE / PART DESCRIPTION: **NOISE ATTENUATOR BOX - FRAME ASSEMBLY (DOOR) (4 of 6)**

DATE CREATED: 13-03-17 | SCALE: NTS | SHEET SIZE: A1
DRAWN BY: I. BUCKLEY | QUOTE No: 1828
CHECKED BY: | JOB No: 2655
ITEM/PART/ASSEMBLY No: | SHEET No: 16 of 28

DRAWING No: 2909-15-025

| REV No | DATE | DESCRIPTION OF CHANGES |
|--------|------------|------------------------|
| 0 | 15/03/2017 | ORIGINAL |
| - | - | - |
| - | - | - |
| - | - | - |

CE EXC 2

DOOR LOCK ASSEMBLY

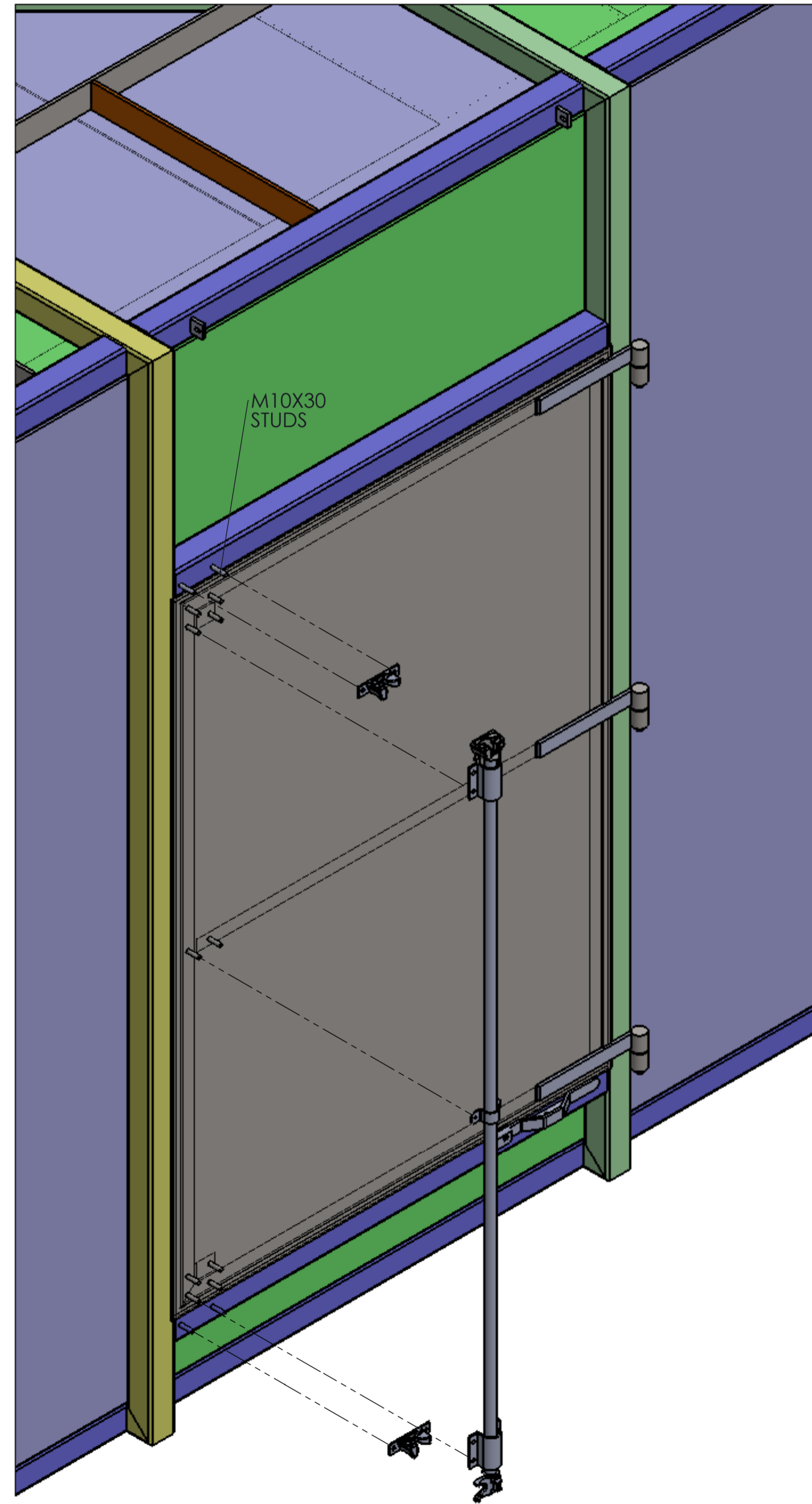

DOOR LOCK PARTS BOUGHT IN EXCEPT Ø 27mm TUBE CUT TO SUIT PICK UP CENTRES OF 2012mm

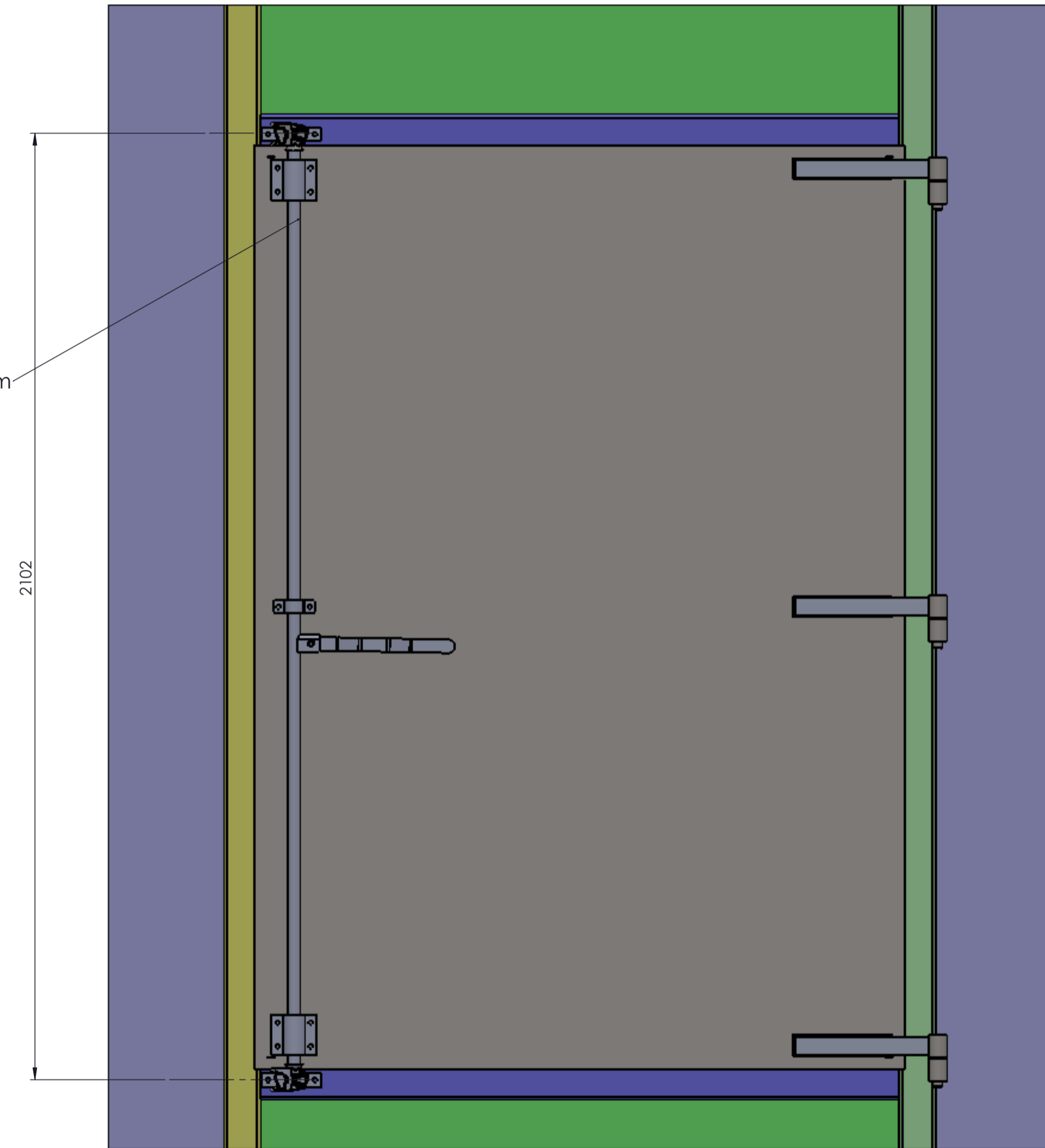

| ITEM NO | QUANTITY | DESCRIPTION | MATERIAL | LENGTH | NOTES | PREWELD INSPECTION | POST WELD INSPECTION |
|---------|----------|---------------------|----------|-------------|-------------|--------------------|----------------------|
| | 1 | CONTAINER DOOR LOCK | 304 | | SUPPLIED | | |
| | 1 | Ø 27 TUBING | 304 | APPROX 2100 | CUT TO SUIT | | |
| | 10 | M10 WASHERS | 304 | | | | |
| | 10 | M10 LOCK NUTS | 304 | | | | |

APPROVAL STAMP

- De Burr all sharp edges
- All welds 6mm leg length fillets unless otherwise stated
- All equally sized box - box T Butt joints will have 2 x 6mm leg fillet welds & 2 x single bevel T butt welds unless otherwise stated
- All dimensions in mm unless otherwise stated
- This drawing remains the property of Noreside engineering
- This drawing may not be copied or passed to a third party without the prior written permission from Noreside engineering

PROJECTION

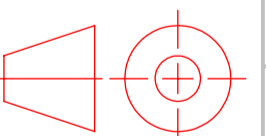

1ST ANGLE

WEIGHT

-

MATERIAL TYPE

STAINLESS 304

QUALITY

CLASS 2

FINISH

BLASTED



Hebron Industrial Estate
Kilkenny, Ireland
email : info@noreside.ie
Telephone : +353 (0) 56 7763966
Fax : +353 (0) 56 7763977

CUSTOMER, CLIENT:

GLANBIA BALLYRAGGET

DRAWING TITLE / PART DESCRIPTION

NOISE ATTENUATOR BOX -
FRAME ASSEMBLY (DOOR LOCK) (5 of 6)

DATE CREATED 13-03-17 SCALE NTS SHEET SIZE A1

DRAWN BY I. BUCKLEY QUOTE No. 1828

CHECKED BY: JOB No. 2655

ITEM/PART/ASSEMBLY No. SHEET No. 17 of 28

DRAWING No. 2909.15.026

REV No. DATE DESCRIPTION OF CHANGES

0 15/03/2017 ORIGINAL

- - -

- - -

- - -



EXC 2

CLEAT & FEET POSITIONS

REAR VIEW

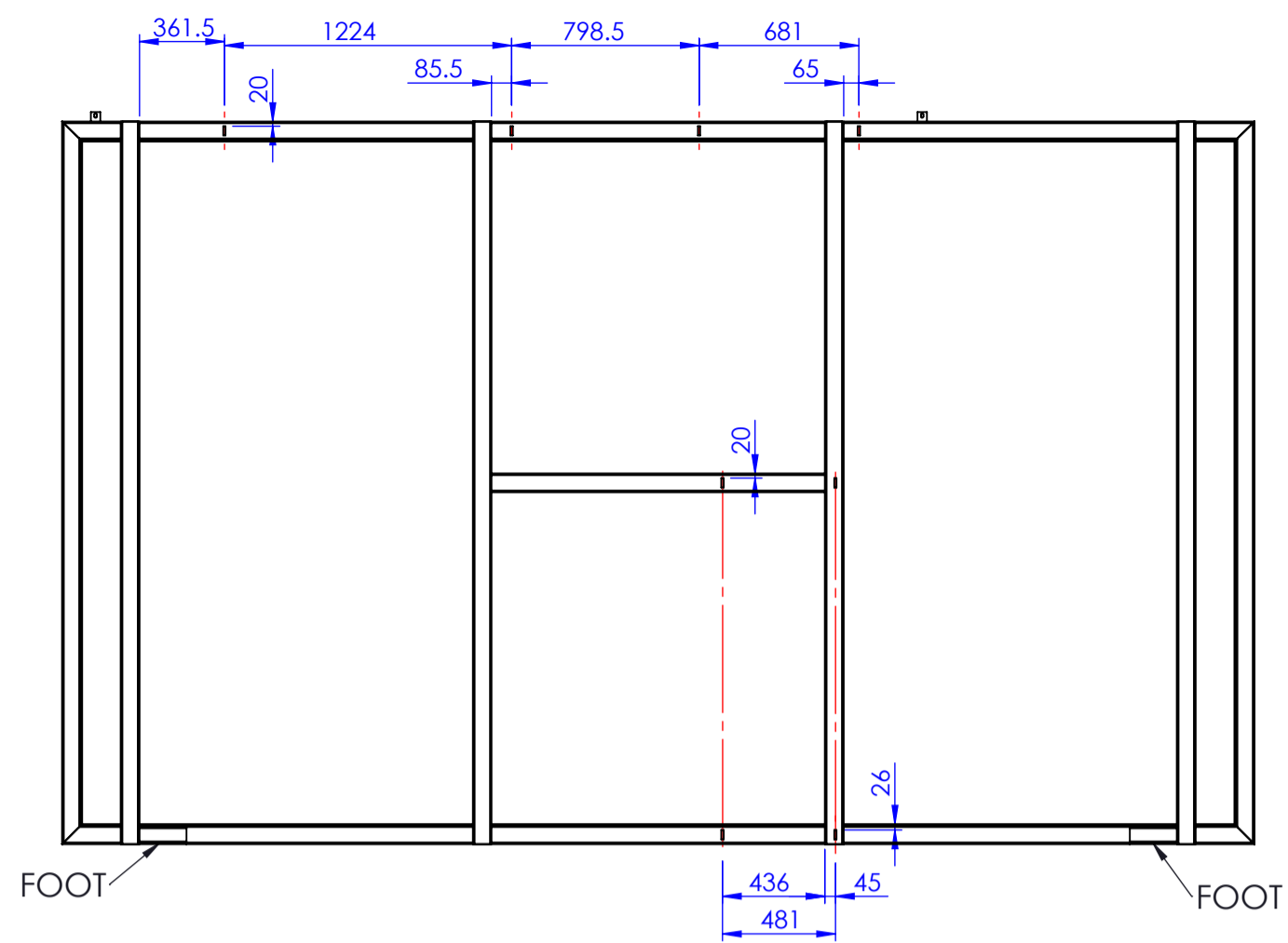

FRONT VIEW

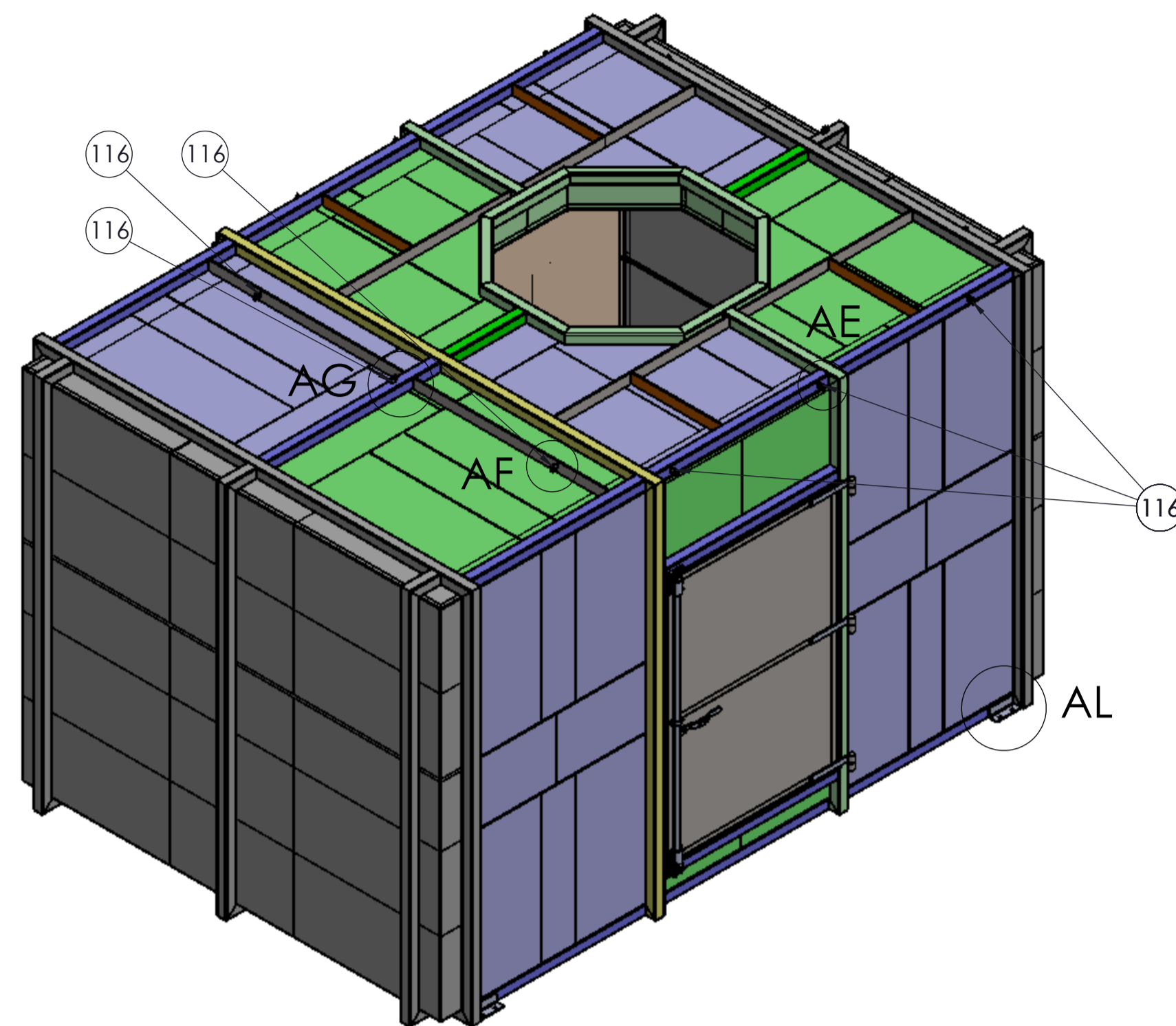

FOOT DRILLING DETAIL
QUANTITY: 4

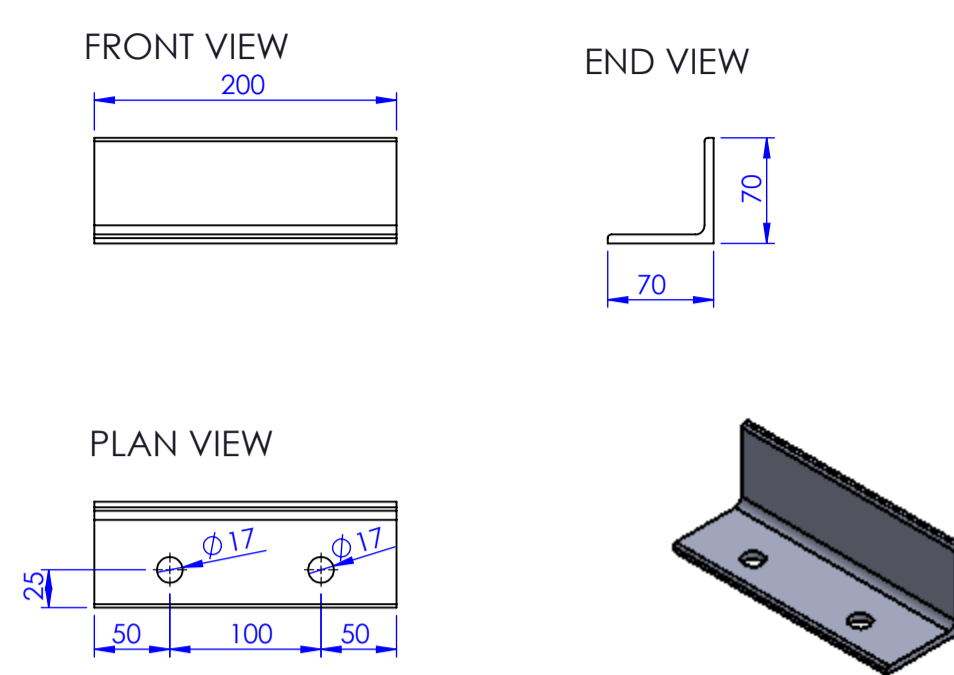

PLAN VIEW

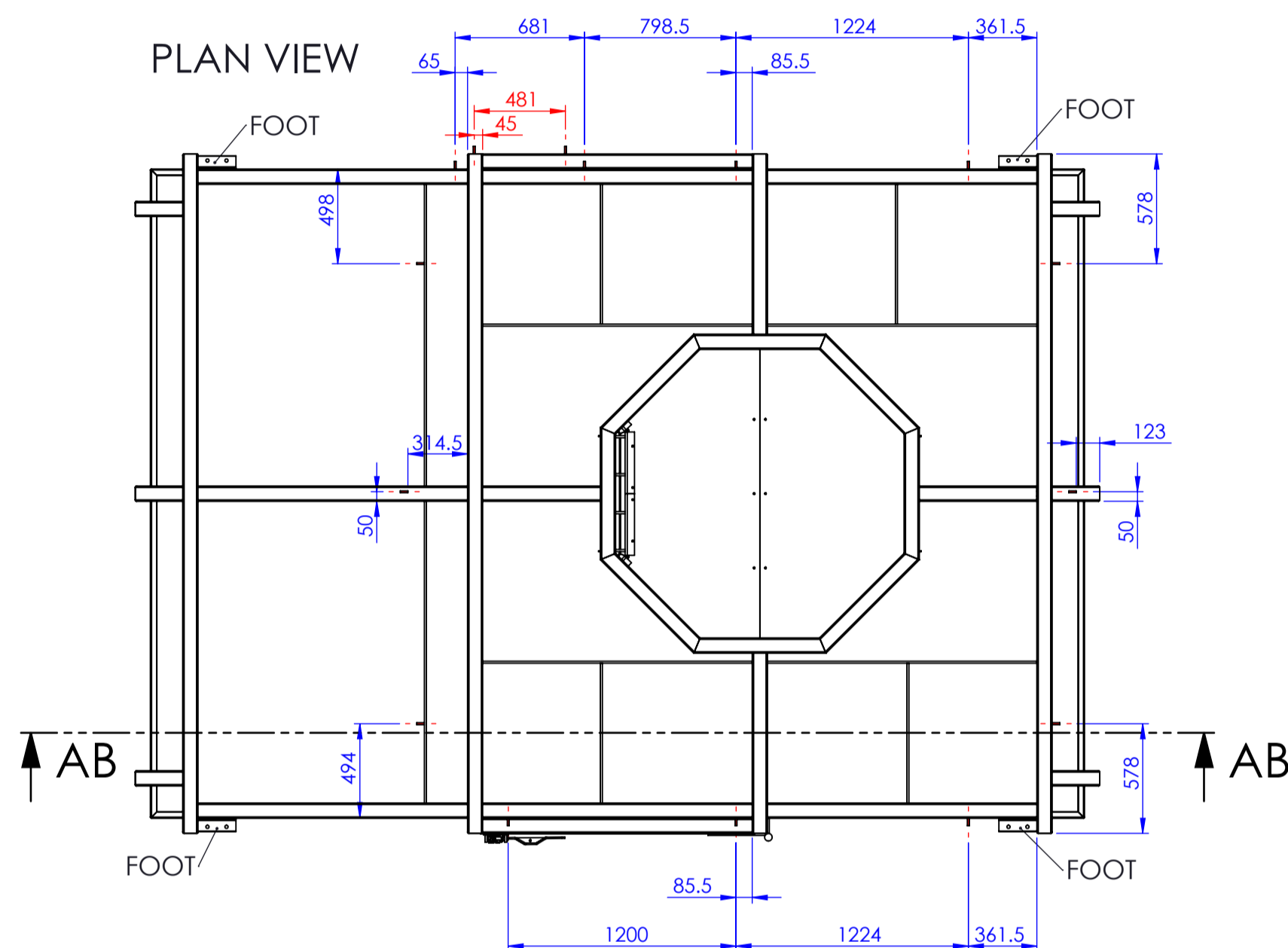

REAR VIEW

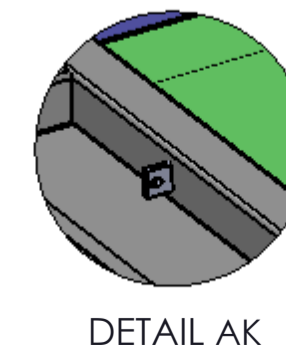
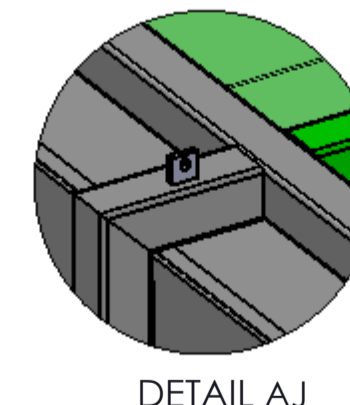
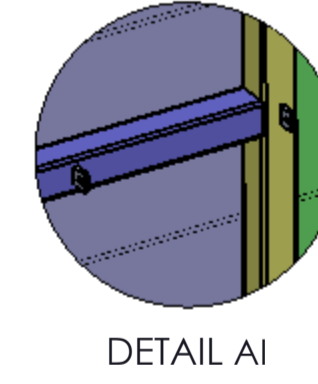
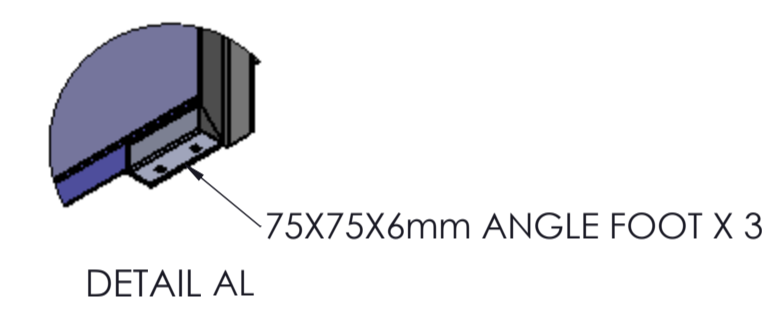
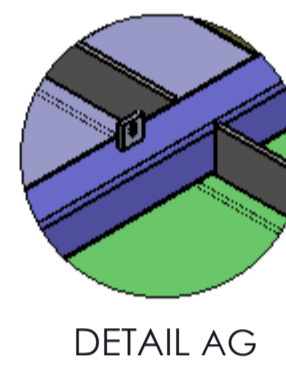
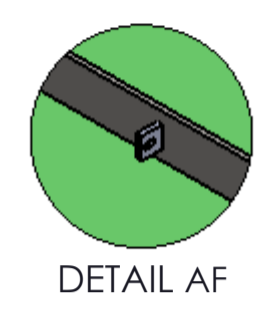
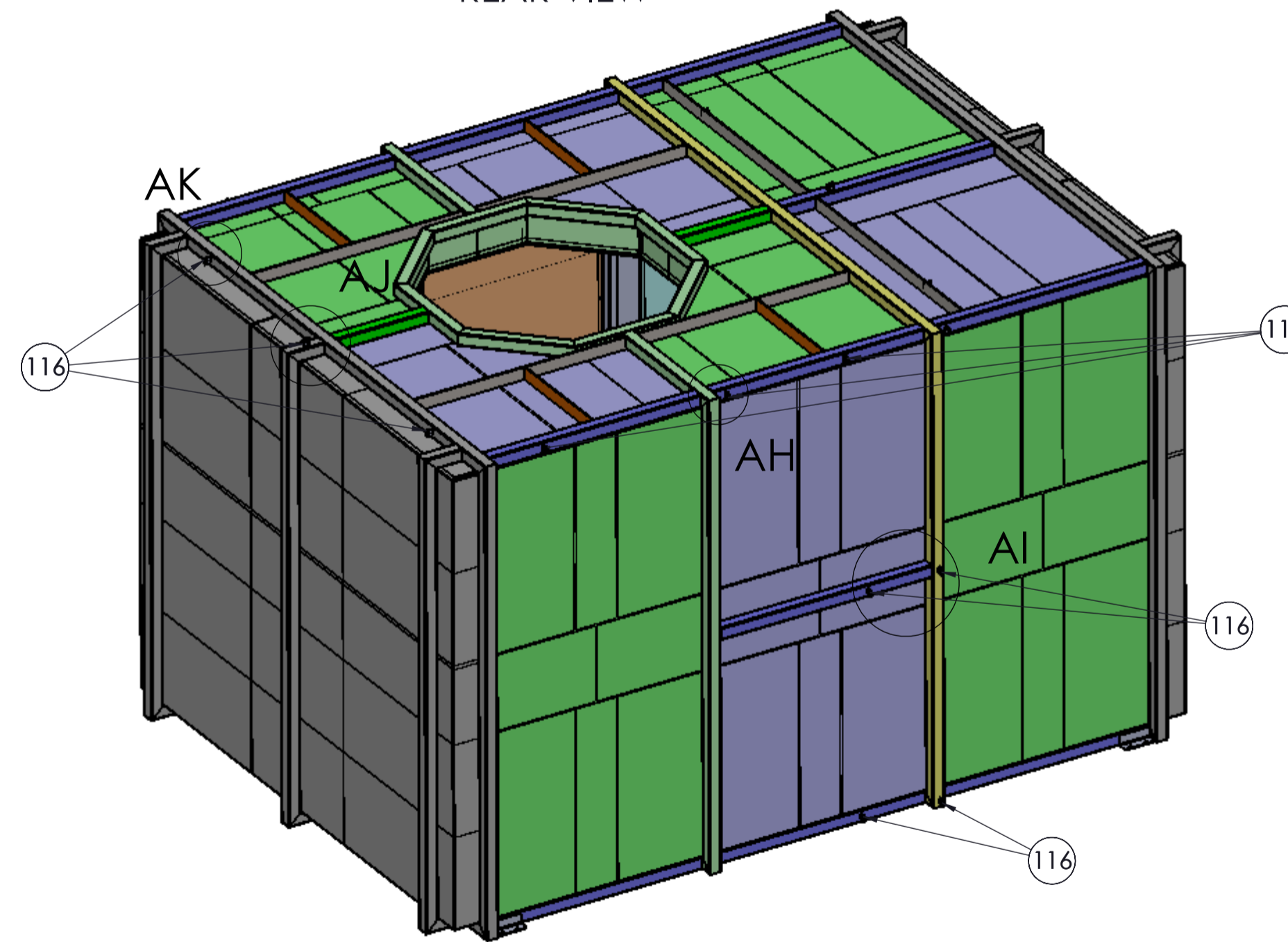

| ITEM NO. | QUANTITY | DESCRIPTION | MATERIAL | LENGTH | NOTES | PREWELD INSPECTION | POST WELD INSPECTION |
|----------|----------|----------------|----------|--------|--------------|--------------------|----------------------|
| 116 | 17 | 10mm LASER CUT | 304 | 40X40 | | | |
| 174 | 4 | 70X70X6 ANGLE | 304 | 200 | CUTTING LIST | | |

FRONT VIEW

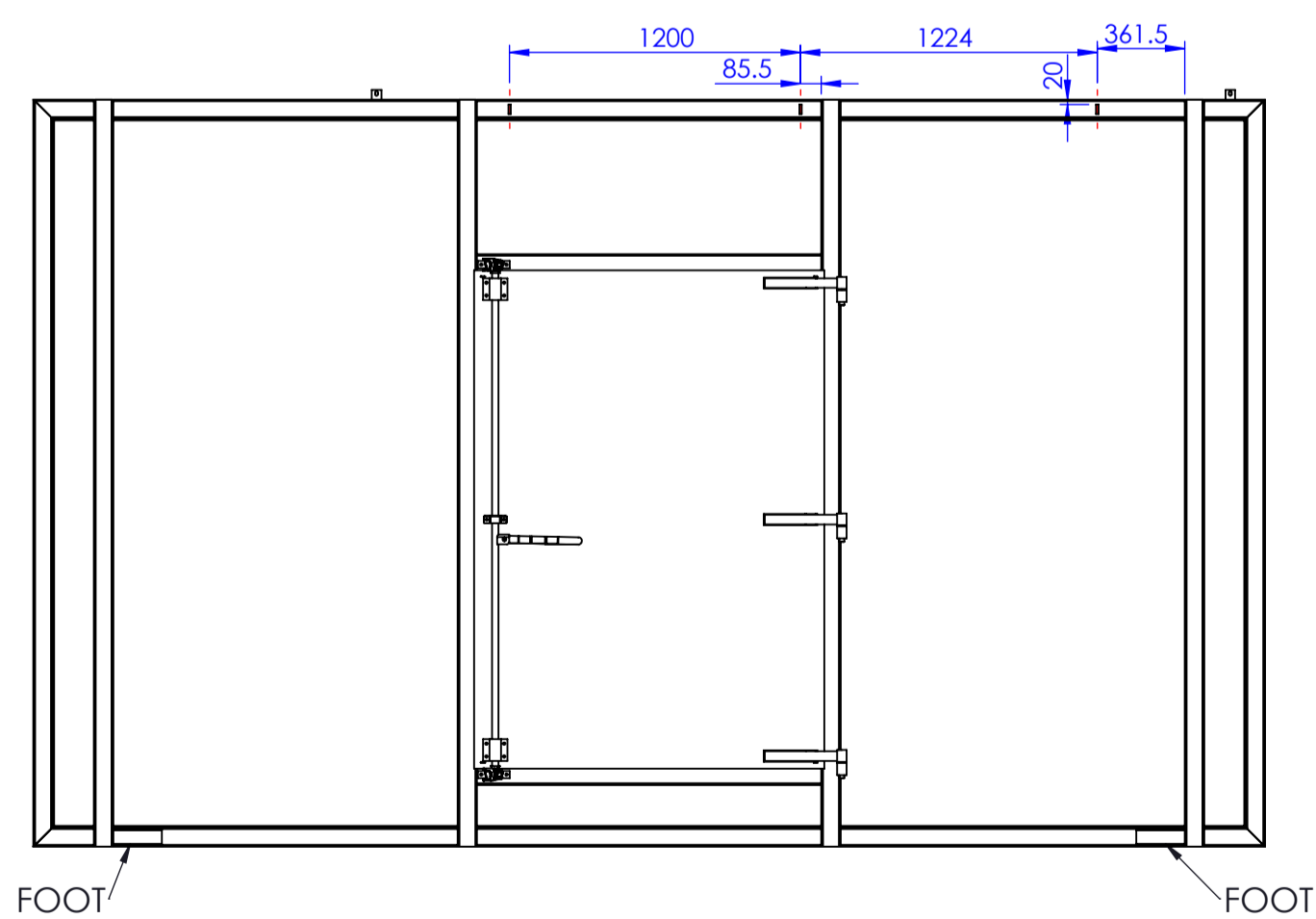

APPROVAL STAMP

- De Burr all sharp edges
 - All welds 6mm leg length fillets unless otherwise stated
 - All equally sized box - box T Butt joints will have 2 x 6mm leg fillet welds & 2 x single bevel T butt welds unless otherwise stated
 - All dimensions in mm unless otherwise stated
 - This drawing remains the property of Noreside engineering
 - This drawing may not be copied or passed to a third party without the prior written permission from Noreside engineering

| | | | |
|---------------|---------------|---------|---------|
| PROJECTION | 1ST ANGLE | WEIGHT | - |
| MATERIAL TYPE | STAINLESS 304 | QUALITY | CLASS 2 |
| FINISH | BLASTED | | |



| | | | |
|--|------------|-----------|----------|
| CUSTOMER, CLIENT | | | |
| GLANBIA BALLYRAGGET | | | |
| DRAWING TITLE / PART DESCRIPTION | | | |
| NOISE ATTENUATOR BOX - FRAME ASSEMBLY (HANDRAIL CLEATS) (6 of 6) | | | |
| DATE CREATED | 13-03-17 | SCALE | NTS |
| DRAWN BY | I. BUCKLEY | QUOTE No. | 1828 |
| CHECKED BY | | JOB No. | 2655 |
| ITEM/PART/ASSEMBLY No. | | SHEET No. | 18 of 28 |



| | | |
|-------------------------|----------|------------------------|
| DRAWING No. 2909.15.027 | | |
| REV No. | DATE | DESCRIPTION OF CHANGES |
| 0 | 13-03-17 | ORIGINAL |
| - | - | - |
| - | - | - |
| - | - | - |

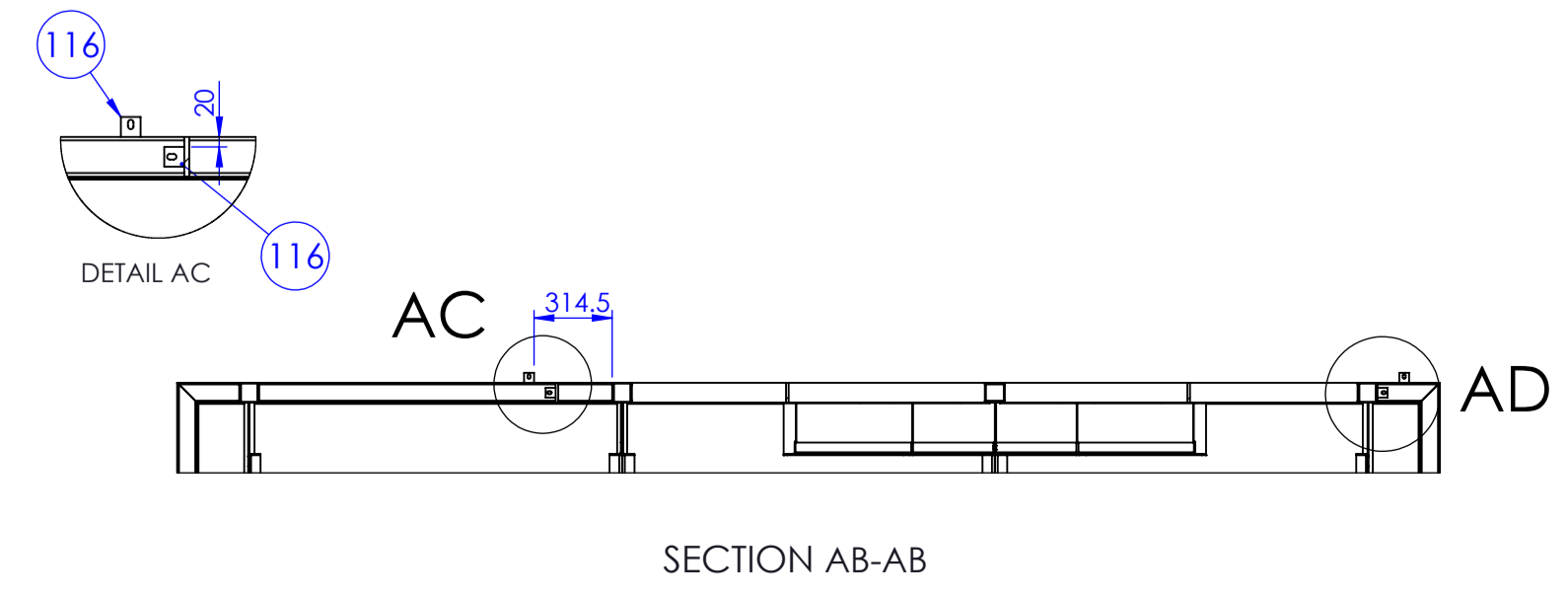

SECTION AB-AB